

# SAA-XC866

8-Bit Single-Chip Microcontroller

# 8bit

Microcontrollers



Never stop thinking

**Edition 2008-02**

**Published by Infineon Technologies AG,  
81726 München, Germany**

**© Infineon Technologies AG 2008.  
All Rights Reserved.**

#### **Legal Disclaimer**

The information given in this document shall in no event be regarded as a guarantee of conditions or characteristics ("Beschaffenheitsgarantie"). With respect to any examples or hints given herein, any typical values stated herein and/or any information regarding the application of the device, Infineon Technologies hereby disclaims any and all warranties and liabilities of any kind, including without limitation warranties of non-infringement of intellectual property rights of any third party.

#### **Information**

For further information on technology, delivery terms and conditions and prices please contact your nearest Infineon Technologies Office ([www.infineon.com](http://www.infineon.com)).

#### **Warnings**

Due to technical requirements components may contain dangerous substances. For information on the types in question please contact your nearest Infineon Technologies Office.

Infineon Technologies Components may only be used in life-support devices or systems with the express written approval of Infineon Technologies, if a failure of such components can reasonably be expected to cause the failure of that life-support device or system, or to affect the safety or effectiveness of that device or system. Life support devices or systems are intended to be implanted in the human body, or to support and/or maintain and sustain and/or protect human life. If they fail, it is reasonable to assume that the health of the user or other persons may be endangered.

# SAA-XC866

8-Bit Single-Chip Microcontroller

Microcontrollers



Never stop thinking

---

**SAA-XC866 Data Sheet****Revision History: 2008-02**V1.2

---

Previous Version: V1.0 2006-11

---

| Page | Subjects (major changes since last revision) |
|------|--|
|------|--|

---

Changes from V1.1 2007-11 to V1.2 2008-02

---

|           |   |
|-----------|---|
| <b>87</b> | Upper limit of power supply voltage is increased from 5.125V to 5.5V. |
|           |   |
|           |   |
|           |   |
|           |   |

---

**We Listen to Your Comments**

Any information within this document that you feel is wrong, unclear or missing at all?  
Your feedback will help us to continuously improve the quality of this document.

Please send your proposal (including a reference to this document) to:

**[mcdocu.comments@infineon.com](mailto:mcdocu.comments@infineon.com)**



## 1 Summary of Features

- High-performance XC800 Core
  - compatible with standard 8051 processor
  - two clocks per machine cycle architecture (for memory access without wait state)
  - two data pointers
- On-chip memory
  - 8 Kbytes of Boot ROM
  - 256 bytes of RAM
  - 512 bytes of XRAM
  - 4/8/16 Kbytes of Flash; or  
8/16 Kbytes of ROM, with additional 4 Kbytes of Flash  
(includes memory protection strategy)
- I/O port supply at 5.0 V and core logic supply at 2.5 V (generated by embedded voltage regulator)

(further features are on next page)

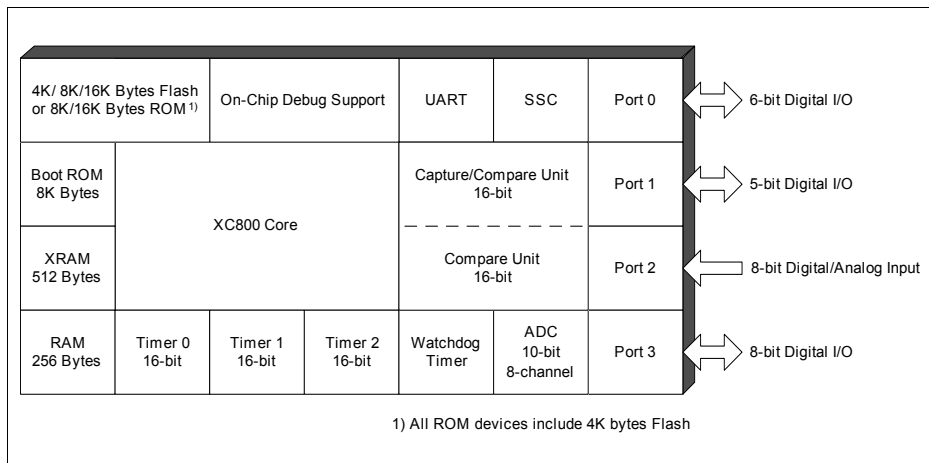

**Figure 1 SAA-XC866 Functional Units**

## Features (continued):

- Reset generation
  - Power-On reset
  - Hardware reset
  - Brownout reset for core logic supply
  - Watchdog timer reset
  - Power-Down Wake-up reset
- On-chip OSC and PLL for clock generation
  - PLL loss-of-lock detection
- Power saving modes
  - slow-down mode
  - idle mode
  - power-down mode with wake-up capability via RXD or EXINT0
  - clock gating control to each peripheral
- Programmable 16-bit Watchdog Timer (WDT)
- Four ports
  - 19 pins as digital I/O
  - 8 pins as digital/analog input
- 8-channel, 10-bit ADC
- Three 16-bit timers
  - Timer 0 and Timer 1 (T0 and T1)
  - Timer 2
- Capture/compare unit for PWM signal generation (CCU6)
- Full-duplex serial interface (UART)
- Synchronous serial channel (SSC)
- On-chip debug support
  - 1 Kbyte of monitor ROM (part of the 8-Kbyte Boot ROM)
  - 64 bytes of monitor RAM
- PG-TSSOP-38 pin package
- Temperature range  $T_A$ :
  - SAA (-40 to 140 °C)

**SAA-XC866 Variant Devices**

The SAA-XC866 product family features devices with different configurations and program memory sizes, offering cost-effective solution for different application requirements.

The list of SAA-XC866 devices and their differences are summarized in [Table 1](#).

**Table 1 Device Summary**

| Device Type         | Device Name     | Power Supply (V) | P-Flash Size (Kbytes) | D-Flash Size (Kbytes) | ROM Size (Kbytes) | LIN BSL Support |
|---------------------|-----------------|------------------|-----------------------|-----------------------|-------------------|-----------------|
| Flash <sup>1)</sup> | SAA-XC866L-4FRA | 5.0              | 12                    | 4                     | –                 | Yes             |
|                     | SAA-XC866-4FRA  | 5.0              | 12                    | 4                     | –                 | No              |
|                     | SAA-XC866L-2FRA | 5.0              | 4                     | 4                     | –                 | Yes             |
|                     | SAA-XC866-2FRA  | 5.0              | 4                     | 4                     | –                 | No              |
|                     | SAA-XC866L-1FRA | 5.0              | –                     | 4                     | –                 | Yes             |
|                     | SAA-XC866-1FRA  | 5.0              | –                     | 4                     | –                 | No              |
| ROM                 | SAA-XC866L-4RRA | 5.0              | –                     | 4                     | 16                | Yes             |
|                     | SAA-XC866-4RRA  | 5.0              | –                     | 4                     | 16                | No              |
|                     | SAA-XC866L-2RRA | 5.0              | –                     | 4                     | 8                 | Yes             |
|                     | SAA-XC866-2RRA  | 5.0              | –                     | 4                     | 8                 | No              |

<sup>1)</sup> The flash memory (P-Flash and D-Flash) can be used for code or data.

**Ordering Information**

The ordering code for Infineon Technologies microcontrollers provides an exact reference to the required product. This ordering code identifies:

- The derivative itself, i.e. its function set, the temperature range, and the supply voltage
- the package and the type of delivery

For the available ordering codes for the SAA-XC866, please refer to your responsible sales representative or your local distributor.

As this document refers to all the derivatives, some descriptions may not apply to a specific product. For simplicity all versions are referred to by the term SAA-XC866 throughout this document.

## 2 General Device Information

### 2.1 Block Diagram

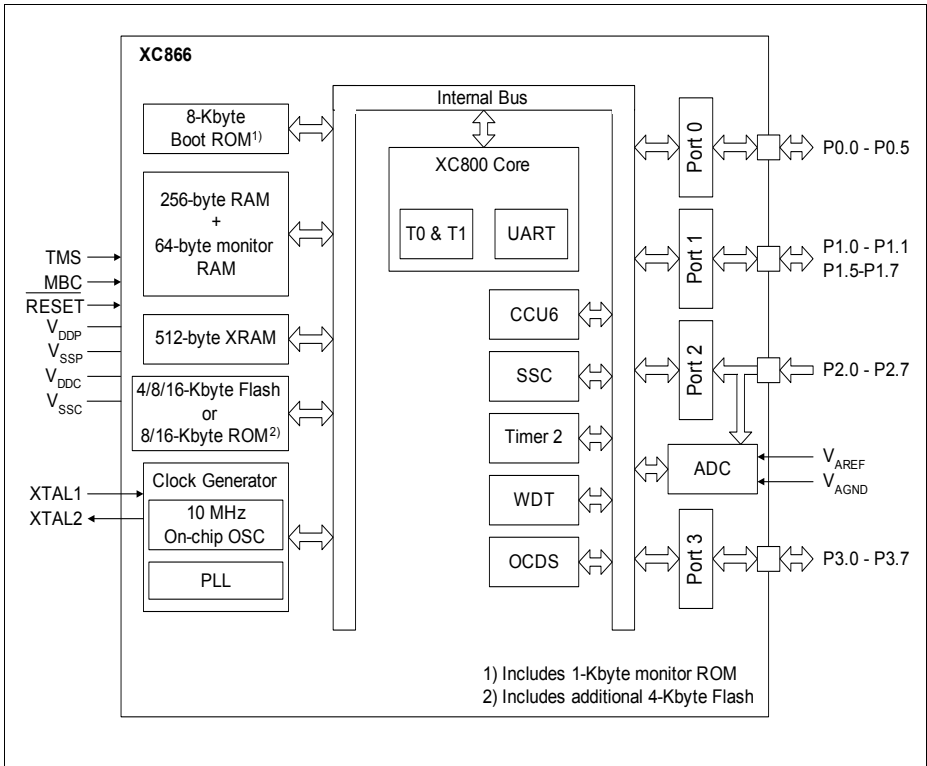
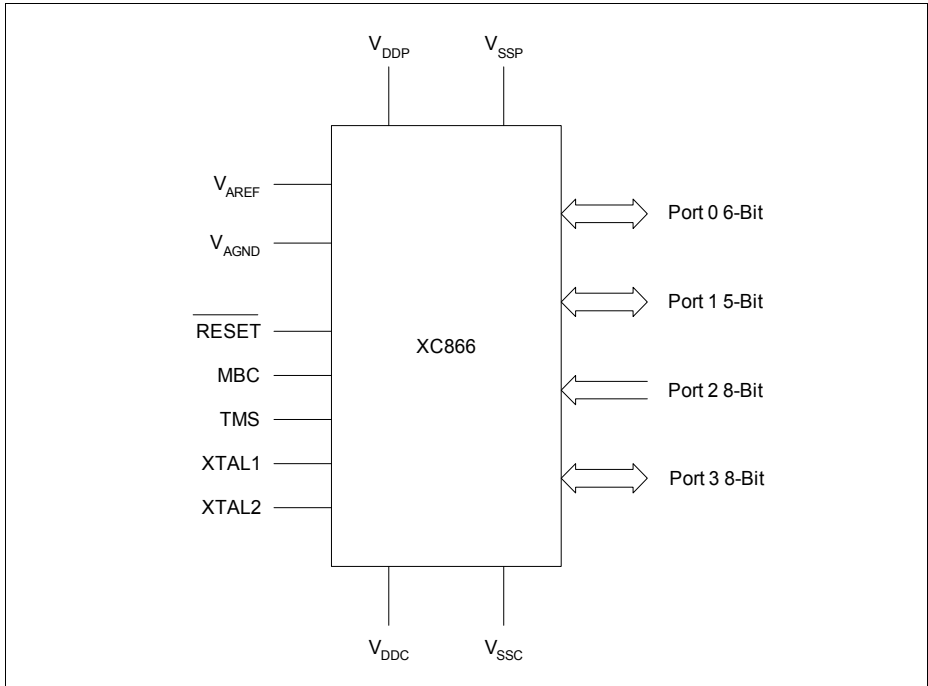

Figure 2 SAA-XC866 Block Diagram



## 2.2 Logic Symbol



**Figure 3 SAA-XC866 Logic Symbol**

### 2.3 Pin Configuration

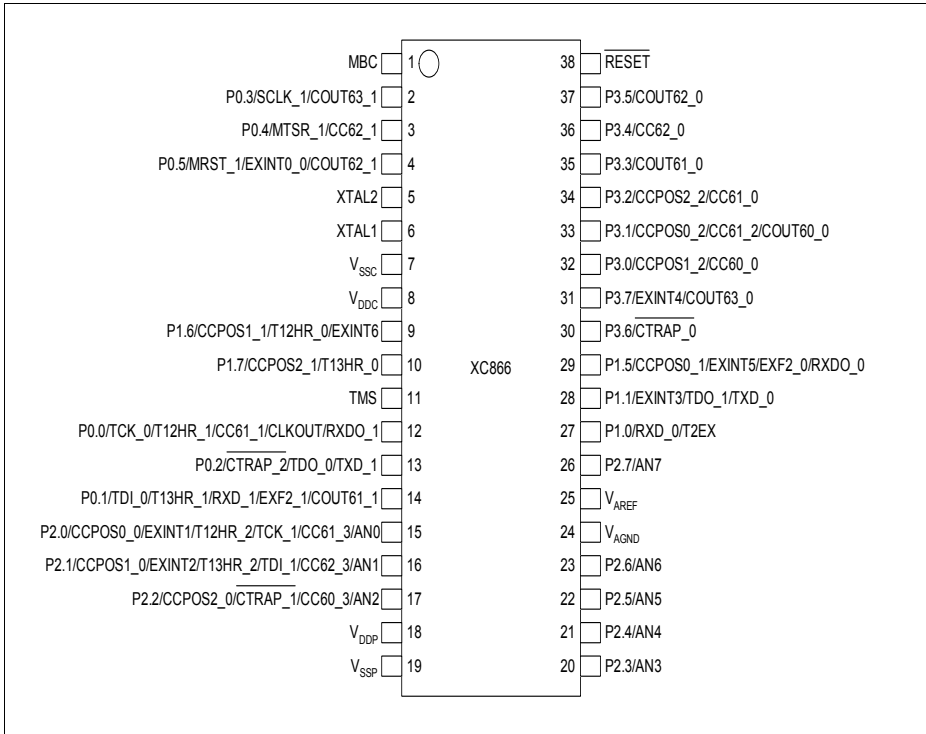

Figure 4 SAA-XC866 Pin Configuration, PG-TSSOP-38 Package (top view)

**2.4 Pin Definitions and Functions**
**Table 2 Pin Definitions and Functions**

| Symbol    | Pin Number | Type | Reset State | Function  |
|-----------|------------|------|-------------|---|
| <b>P0</b> |            | I/O  |             | <b>Port 0</b><br>Port 0 is a 6-bit bidirectional general purpose I/O port. It can be used as alternate functions for the JTAG, CCU6, UART, and the SSC.   |
| P0.0      | 12         |      | Hi-Z        | TCK_0 JTAG Clock Input<br>T12HR_1 CCU6 Timer 12 Hardware Run Input<br>CC61_1 Input/Output of Capture/Compare channel 1<br>CLKOUT Clock Output<br>RXDO_1 UART Transmit Data Output               |
| P0.1      | 14         |      | Hi-Z        | TDI_0 JTAG Serial Data Input<br>T13HR_1 CCU6 Timer 13 Hardware Run Input<br>RXD_1 UART Receive Data Input<br>COU61_1 Output of Capture/Compare channel 1<br>EXF2_1 Timer 2 External Flag Output |
| P0.2      | 13         |      | PU          | CTRAP_2 CCU6 Trap Input<br>TDO_0 JTAG Serial Data Output<br>TXD_1 UART Transmit Data Output/<br>Clock Output  |
| P0.3      | 2          |      | Hi-Z        | SCK_1 SSC Clock Input/Output<br>COU63_1 Output of Capture/Compare channel 3   |
| P0.4      | 3          |      | Hi-Z        | MTSR_1 SSC Master Transmit Output/<br>Slave Receive Input<br>CC62_1 Input/Output of Capture/Compare channel 2   |
| P0.5      | 4          |      | Hi-Z        | MRST_1 SSC Master Receive Input/<br>Slave Transmit Output<br>EXINT0_0 External Interrupt Input 0<br>COU62_1 Output of Capture/Compare channel 2   |

General Device Information

Table 2 Pin Definitions and Functions (cont'd)

| Symbol    | Pin Number | Type | Reset State | Function  |
|-----------|------------|------|-------------|---|
| <b>P1</b> |            | I/O  |             | <b>Port 1</b><br>Port 1 is a 5-bit bidirectional general purpose I/O port. It can be used as alternate functions for the JTAG, CCU6, UART, and the SSC. |
| P1.0      | 27         |      | PU          | RXD_0 UART Receive Data Input<br>T2EX Timer 2 External Trigger Input  |
| P1.1      | 28         |      | PU          | EXINT3 External Interrupt Input 3<br>TDO_1 JTAG Serial Data Output<br>TXD_0 UART Transmit Data Output/<br>Clock Output                                  |
| P1.5      | 29         |      | PU          | CCPOS0_1 CCU6 Hall Input 0<br>EXINT5 External Interrupt Input 5<br>EXF2_0 Timer 2 External Flag Output<br>RXDO_0 UART Transmit Data Output              |
| P1.6      | 9          |      | PU          | CCPOS1_1 CCU6 Hall Input 1<br>T12HR_0 CCU6 Timer 12 Hardware Run<br>Input   |
| P1.7      | 10         |      | PU          | EXINT6 External Interrupt Input 6<br>CCPOS2_1 CCU6 Hall Input 2<br>T13HR_0 CCU6 Timer 13 Hardware Run<br>Input  |
|           |            |      |             | P1.5 and P1.6 can be used as a software chip select output for the SSC.   |

General Device Information

Table 2 Pin Definitions and Functions (cont'd)

| Symbol    | Pin Number | Type | Reset State | Function   |
|-----------|------------|------|-------------|--|
| <b>P2</b> |            | I    |             | <b>Port 2</b><br>Port 2 is an 8-bit general purpose input-only port. It can be used as alternate functions for the digital inputs of the JTAG and CCU6. It is also used as the analog inputs for the ADC.      |
| P2.0      | 15         |      | Hi-Z        | CCPOS0_0 CCU6 Hall Input 0<br>EXINT1 External Interrupt Input 1<br>T12HR_2 CCU6 Timer 12 Hardware Run Input<br>TCK_1 JTAG Clock Input<br>CC61_3 Input of Capture/Compare channel 1<br>AN0 Analog Input 0       |
| P2.1      | 16         |      | Hi-Z        | CCPOS1_0 CCU6 Hall Input 1<br>EXINT2 External Interrupt Input 2<br>T13HR_2 CCU6 Timer 13 Hardware Run Input<br>TDI_1 JTAG Serial Data Input<br>CC62_3 Input of Capture/Compare channel 2<br>AN1 Analog Input 1 |
| P2.2      | 17         |      | Hi-Z        | CCPOS2_0 CCU6 Hall Input 2<br>CTRAP_1 CCU6 Trap Input<br>CC60_3 Input of Capture/Compare channel 0<br>AN2 Analog Input 2   |
| P2.3      | 20         |      | Hi-Z        | AN3 Analog Input 3   |
| P2.4      | 21         |      | Hi-Z        | AN4 Analog Input 4   |
| P2.5      | 22         |      | Hi-Z        | AN5 Analog Input 5   |
| P2.6      | 23         |      | Hi-Z        | AN6 Analog Input 6   |
| P2.7      | 26         |      | Hi-Z        | AN7 Analog Input 7   |

General Device Information

Table 2 Pin Definitions and Functions (cont'd)

| Symbol    | Pin Number | Type | Reset State | Function   |
|-----------|------------|------|-------------|--|
| <b>P3</b> |            | I    |             | <b>Port 3</b><br>Port 3 is a bidirectional general purpose I/O port. It can be used as alternate functions for the CCU6.       |
| P3.0      | 32         |      | Hi-Z        | CCPOS1_2 CCU6 Hall Input 1<br>CC60_0 Input/Output of Capture/Compare channel 0   |
| P3.1      | 33         |      | Hi-Z        | CCPOS0_2 CCU6 Hall Input 0<br>CC61_2 Input/Output of Capture/Compare channel 1<br>COUT60_0 Output of Capture/Compare channel 0 |
| P3.2      | 34         |      | Hi-Z        | CCPOS2_2 CCU6 Hall Input 2<br>CC61_0 Input/Output of Capture/Compare channel 1   |
| P3.3      | 35         |      | Hi-Z        | COUT61_0 Output of Capture/Compare channel 1   |
| P3.4      | 36         |      | Hi-Z        | CC62_0 Input/Output of Capture/Compare channel 2   |
| P3.5      | 37         |      | Hi-Z        | COUT62_0 Output of Capture/Compare channel 2   |
| P3.6      | 30         |      | PD          | <u>CTRAP_0</u> CCU6 Trap Input   |
| P3.7      | 31         |      | Hi-Z        | EXINT4 External Interrupt Input 4<br>COUT63_0 Output of Capture/Compare channel 3  |

**Table 2 Pin Definitions and Functions (cont'd)**

| Symbol            | Pin Number | Type | Reset State | Function   |
|-------------------|------------|------|-------------|--|
| $V_{DDP}$         | 18         | –    | –           | I/O Port Supply (5.0 V)                          |
| $V_{SSP}$         | 19         | –    | –           | I/O Port Ground                                  |
| $V_{DDC}$         | 8          | –    | –           | Core Supply Monitor (2.5 V)                      |
| $V_{SSC}$         | 7          | –    | –           | Core Supply Ground                               |
| $V_{AREF}$        | 25         | –    | –           | ADC Reference Voltage                            |
| $V_{AGND}$        | 24         | –    | –           | ADC Reference Ground                             |
| XTAL1             | 6          | I    | Hi-Z        | External Oscillator Input<br>(NC if not needed)  |
| XTAL2             | 5          | O    | Hi-Z        | External Oscillator Output<br>(NC if not needed) |
| TMS               | 11         | I    | PD          | Test Mode Select                                 |
| RESET             | 38         | I    | PU          | Reset Input                                      |
| MBC <sup>1)</sup> | 1          | I    | PU          | Monitor & BootStrap Loader Control               |

<sup>1)</sup> An external pull-up device in the range of 4.7 k $\Omega$  to 100 k $\Omega$  is required to enter user mode. Alternatively MBC can be tied to high if alternate functions (for debugging) of the pin are not utilized.

### 3 Functional Description

#### 3.1 Processor Architecture

The SAA-XC866 is based on a high-performance 8-bit Central Processing Unit (CPU) that is compatible with the standard 8051 processor. While the standard 8051 processor is designed around a 12-clock machine cycle, the SAA-XC866 CPU uses a 2-clock machine cycle. This allows fast access to ROM or RAM memories without wait state. Access to the Flash memory, however, requires an additional wait state (one machine cycle). The instruction set consists of 45% one-byte, 41% two-byte and 14% three-byte instructions.

The SAA-XC866 CPU provides a range of debugging features, including basic stop/start, single-step execution, breakpoint support and read/write access to the data memory, program memory and SFRs. **Figure 5** shows the CPU functional blocks.

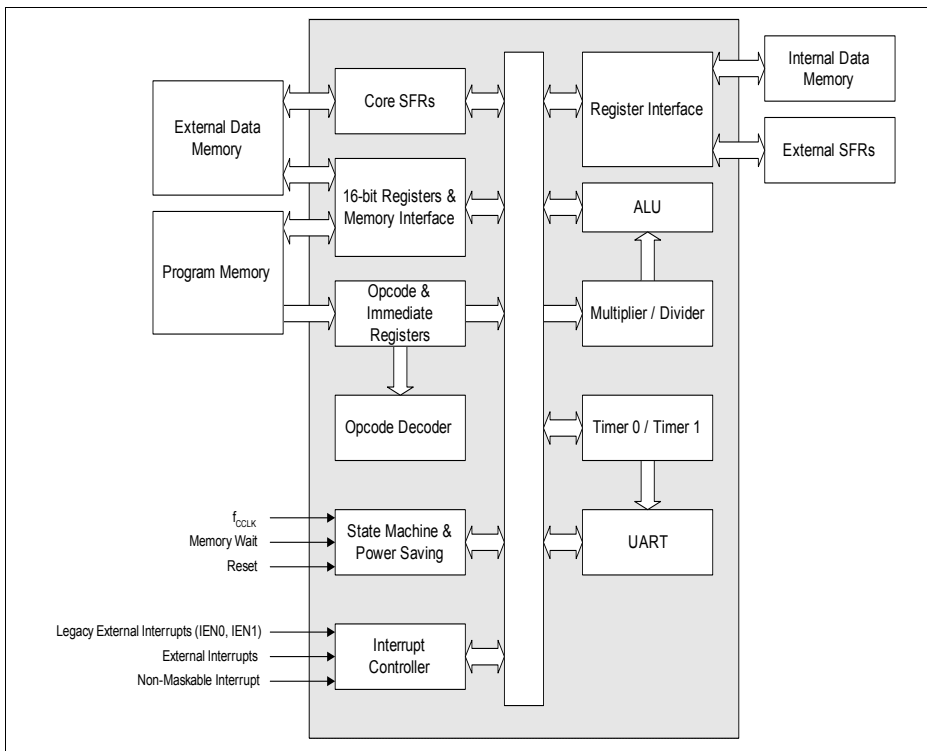

**Figure 5 CPU Block Diagram**



### **3.2 Memory Organization**

The SAA-XC866 CPU operates in the following five address spaces:

- 8 Kbytes of Boot ROM program memory
- 256 bytes of internal RAM data memory
- 512 bytes of XRAM memory
- a 128-byte Special Function Register area
- 4/8/16 Kbytes of Flash program memory (Flash devices); or  
8/16 Kbytes of ROM program memory, with additional 4 Kbytes of Flash (ROM devices)

Functional Description

Figure 6 illustrates the memory address spaces of the SAA-XC866-4FR devices.

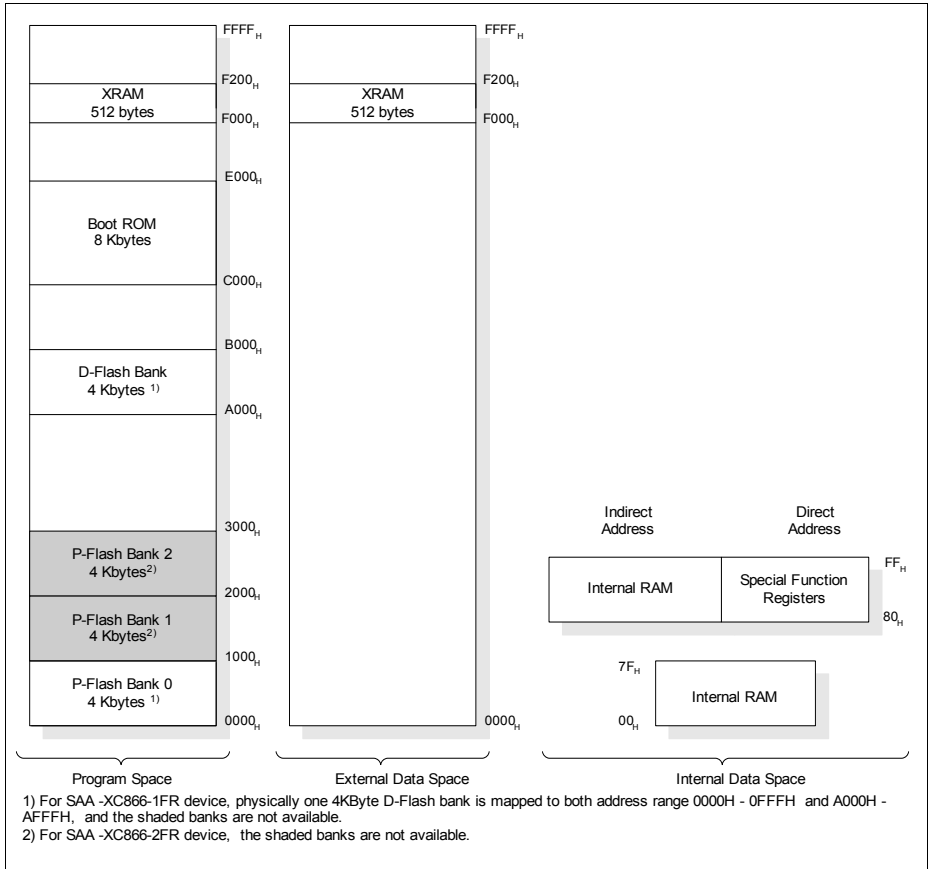

Figure 6 Memory Map of SAA-XC866 Flash Devices

Functional Description

Figure 7 illustrates the memory address spaces of the SAA-XC866-4RR device.

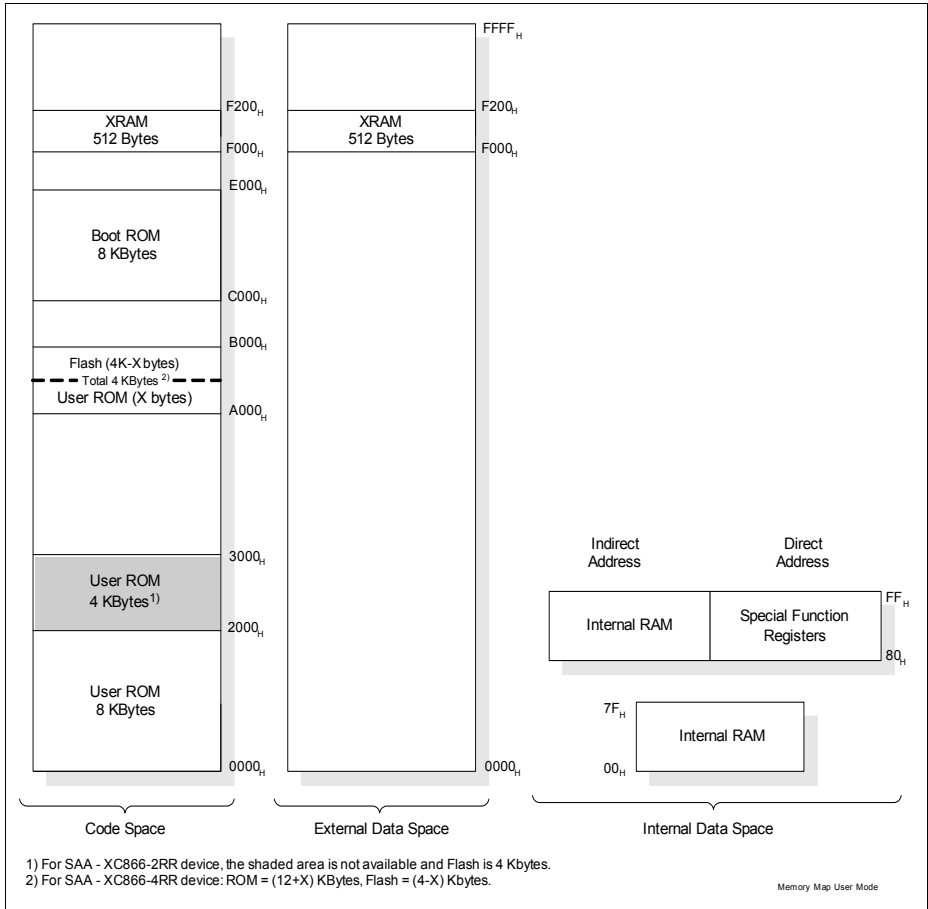

Figure 7 Memory Map of SAA-XC866 ROM Devices

### 3.2.1 Memory Protection Strategy

The SAA-XC866 memory protection strategy includes:

- Read-out protection: The Flash Memory can be enabled for read-out protection and ROM memory is always protected.
- Program and erase protection: The Flash memory in all devices can be enabled for program and erase protection.

Flash memory protection is available in two modes:

- Mode 0: Only the P-Flash is protected; the D-Flash is unprotected
- Mode 1: Both the P-Flash and D-Flash are protected

The selection of each protection mode and the restrictions imposed are summarized in [Table 3](#).

**Table 3 Flash Protection Modes**

| Mode                                   | 0   | 1   |
|--|---|---|
| <b>Activation</b>                      | Program a valid password via BSL mode 6   |   |
| <b>Selection</b>                       | MSB of password = 0   | MSB of password = 1                         |
| <b>P-Flash contents can be read by</b> | Read instructions in the P-Flash  | Read instructions in the P-Flash or D-Flash |
| <b>P-Flash program and erase</b>       | Not possible  | Not possible                                |
| <b>D-Flash contents can be read by</b> | Read instructions in any program memory   | Read instructions in the P-Flash or D-Flash |
| <b>D-Flash program</b>                 | Possible  | Not possible                                |
| <b>D-Flash erase</b>                   | Possible, on the condition that bit DFLASHEN in register MISC_CON is set to 1 prior to each erase operation | Not possible                                |

BSL mode 6, which is used for enabling Flash protection, can also be used for disabling Flash protection. Here, the programmed password must be provided by the user. A password match triggers an automatic erase of the read-protected Flash contents, see [Table 4](#) and [Table 5](#), and the programmed password is erased. The Flash protection is then disabled upon the next reset.

**For XC866-2FR and XC866-4FR devices:**

The selection of protection type is summarized in [Table 4](#).

**Table 4 Flash Protection Type for XC866-2FR and XC866-4FR devices**

| <b>PASSWORD</b>        | <b>Type of Protection</b> | <b>Flash Banks to Erase when Unprotected</b> |
|------------------------|---------------------------|--|
| 1XXXXXXXX <sub>B</sub> | Flash Protection Mode 1   | All Banks                                    |
| 0XXXXXXXX <sub>B</sub> | Flash Protection Mode 0   | P-Flash Bank                                 |

**For XC866-1FR device and ROM devices:**

The selection of protection type is summarized in [Table 5](#).

**Table 5 Flash Protection Type for XC866-1FR device and ROM devices**

| <b>PASSWORD</b>        | <b>Type of Protection (Applicable to the whole Flash)</b> | <b>Sectors to Erase when Unprotected</b> | <b>Comments</b>                 |
|------------------------|---|--|---------------------------------|
| 1XXXXXXXX <sub>B</sub> | Read/Program/Erase  | All Sectors                              | Compatible to Protection mode 1 |
| 00001XXX <sub>B</sub>  | Erase   | Sector 0                                 |                                 |
| 00010XXX <sub>B</sub>  | Erase   | Sector 0 and 1                           |                                 |
| 00011XXX <sub>B</sub>  | Erase   | Sector 0 to 2                            |                                 |
| 00100XXX <sub>B</sub>  | Erase   | Sector 0 to 3                            |                                 |
| 00101XXX <sub>B</sub>  | Erase   | Sector 0 to 4                            |                                 |
| 00110XXX <sub>B</sub>  | Erase   | Sector 0 to 5                            |                                 |
| 00111XXX <sub>B</sub>  | Erase   | Sector 0 to 6                            |                                 |
| 01000XXX <sub>B</sub>  | Erase   | Sector 0 to 7                            |                                 |
| 01001XXX <sub>B</sub>  | Erase   | Sector 0 to 8                            |                                 |
| 01010XXX <sub>B</sub>  | Erase   | All Sectors                              |                                 |
| Others                 | Erase   | None                                     |                                 |

Although no protection scheme can be considered infallible, the SAA-XC866 memory protection strategy provides a very high level of protection for a general purpose microcontroller.

### 3.2.2 Special Function Register

The Special Function Registers (SFRs) occupy direct internal data memory space in the range 80<sub>H</sub> to FF<sub>H</sub>. All registers, except the program counter, reside in the SFR area. The SFRs include pointers and registers that provide an interface between the CPU and the on-chip peripherals. As the 128-SFR range is less than the total number of registers required, address extension mechanisms are required to increase the number of addressable SFRs. The address extension mechanisms include:

- Mapping
- Paging

#### 3.2.2.1 Address Extension by Mapping

Address extension is performed at the system level by mapping. The SFR area is extended into two portions: the standard (non-mapped) SFR area and the mapped SFR area. Each portion supports the same address range 80<sub>H</sub> to FF<sub>H</sub>, bringing the number of addressable SFRs to 256. The extended address range is not directly controlled by the CPU instruction itself, but is derived from bit RMAP in the system control register SYSCON0 at address 8F<sub>H</sub>. To access SFRs in the mapped area, bit RMAP in SFR SYSCON0 must be set. Alternatively, the SFRs in the standard area can be accessed by clearing bit RMAP. The SFR area can be selected as shown in [Figure 8](#).

#### SYSCON0

##### System Control Register 0

Reset Value: 00<sub>H</sub>

|   |   |   |   |   |    |   |      |
|---|---|---|---|---|----|---|------|
| 7 | 6 | 5 | 4 | 3 | 2  | 1 | 0    |
| 0 |   |   |   |   | 1  | 0 | RMAP |
| r |   |   |   |   | rw | r | rw   |

| Field | Bits    | Type | Description  |
|-------|---------|------|--|
| RMAP  | 0       | rw   | <b>Special Function Register Map Control</b><br>0 The access to the standard SFR area is enabled.<br>1 The access to the mapped SFR area is enabled. |
| 1     | 2       | rw   | <b>Reserved</b><br>Returns the last value if read; should be written with 1.   |
| 0     | 1,[7:3] | r    | <b>Reserved</b><br>Returns 0 if read; should be written with 0.  |

**Functional Description**

*Note: The RMAP bit must be cleared/set by ANL or ORL instructions. The rest bits of SYSCON0 should not be modified.*

As long as bit RMAP is set, the mapped SFR area can be accessed. This bit is not cleared automatically by hardware. Thus, before standard/mapped registers are accessed, bit RMAP must be cleared/set, respectively, by software.

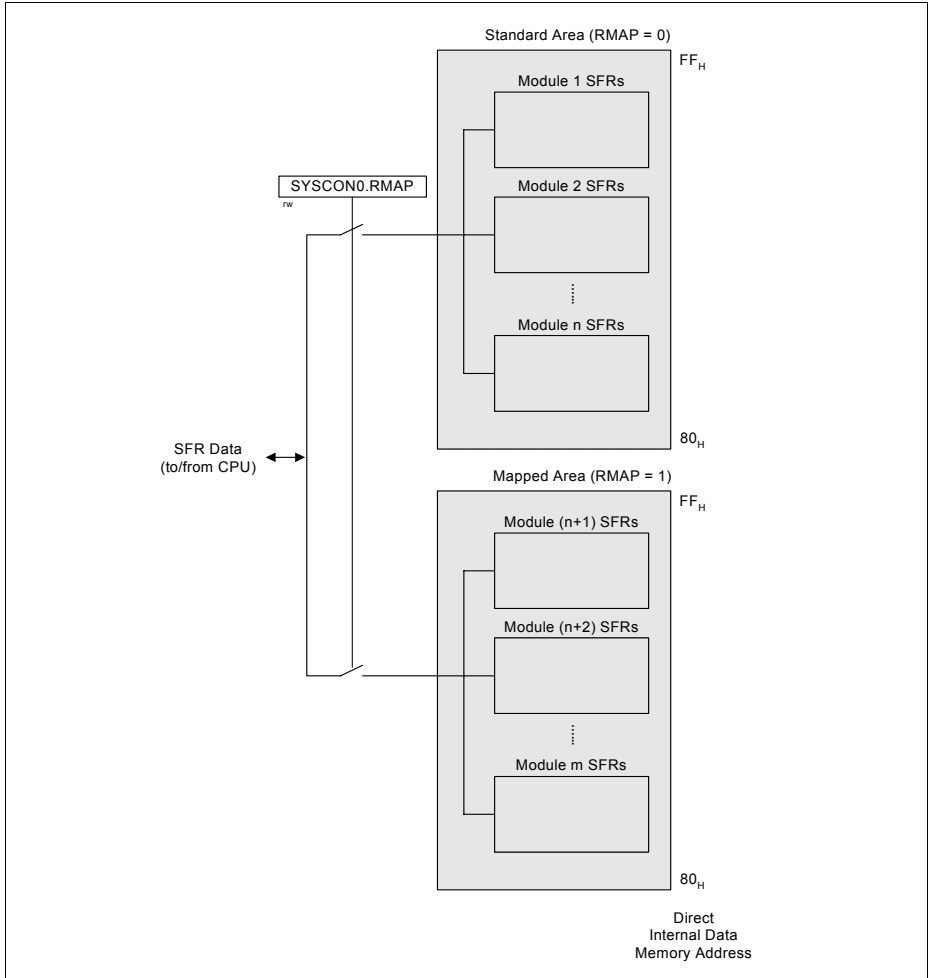

**Figure 8 Address Extension by Mapping**

### 3.2.2.2 Address Extension by Paging

Address extension is further performed at the module level by paging. With the address extension by mapping, the SAA-XC866 has a 256-SFR address range. However, this is still less than the total number of SFRs needed by the on-chip peripherals. To meet this requirement, some peripherals have a built-in local address extension mechanism for increasing the number of addressable SFRs. The extended address range is not directly controlled by the CPU instruction itself, but is derived from bit field PAGE in the module page register MOD\_PAGE. Hence, the bit field PAGE must be programmed before accessing the SFR of the target module. Each module may contain a different number of pages and a different number of SFRs per page, depending on the specific requirement. Besides setting the correct RMAP bit value to select the SFR area, the user must also ensure that a valid PAGE is selected to target the desired SFR. A page inside the extended address range can be selected as shown in **Figure 9**.

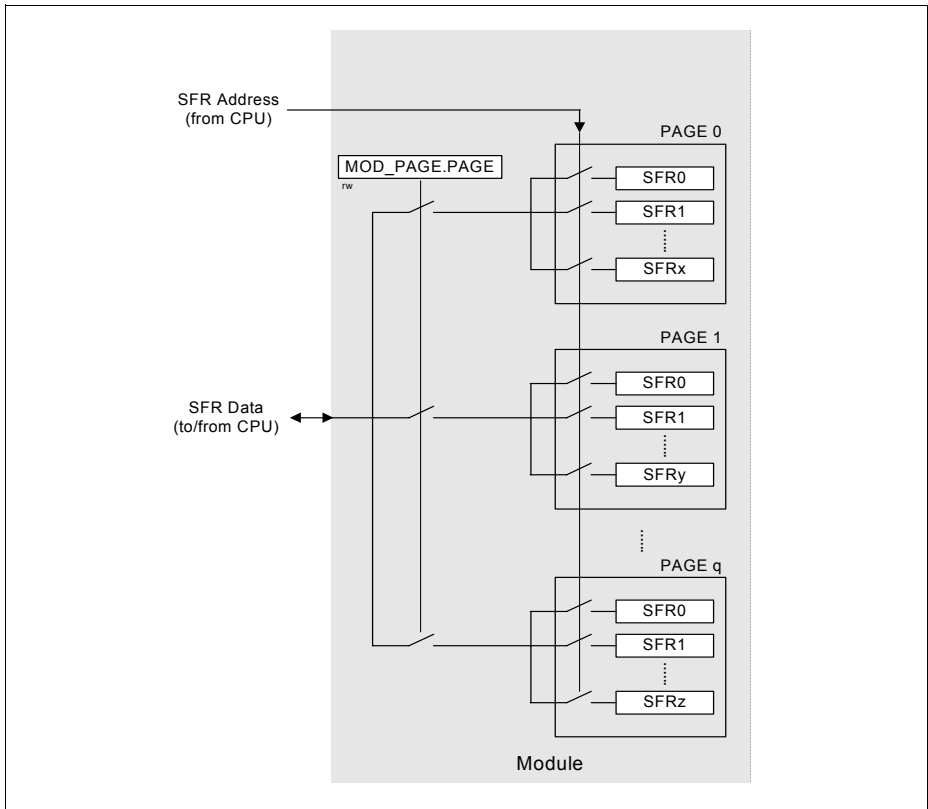

**Figure 9** Address Extension by Paging



**Functional Description**

In order to access a register located in a page different from the actual one, the current page must be left. This is done by reprogramming the bit field PAGE in the page register. Only then can the desired access be performed.

If an interrupt routine is initiated between the page register access and the module register access, and the interrupt needs to access a register located in another page, the current page setting can be saved, the new one programmed and finally, the old page setting restored. This is possible with the storage fields STx (x = 0 - 3) for the save and restore action of the current page setting. By indicating which storage bit field should be used in parallel with the new page value, a single write operation can:

- Save the contents of PAGE in STx before overwriting with the new value (this is done in the beginning of the interrupt routine to save the current page setting and program the new page number); or
- Overwrite the contents of PAGE with the contents of STx, ignoring the value written to the bit positions of PAGE (this is done at the end of the interrupt routine to restore the previous page setting before the interrupt occurred)

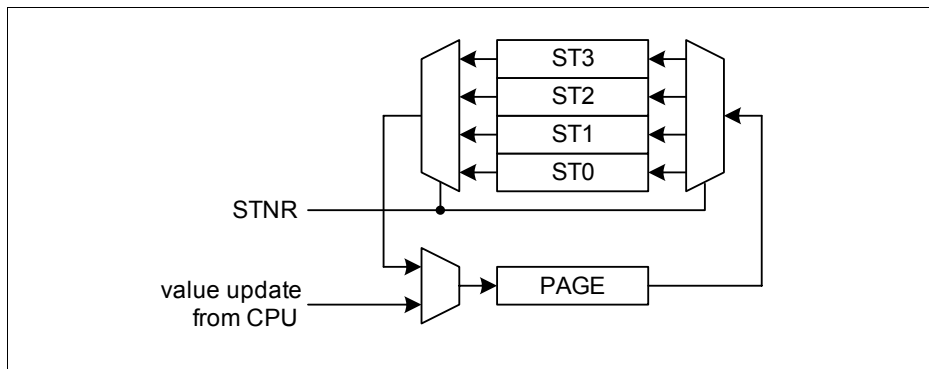

**Figure 10 Storage Elements for Paging**

With this mechanism, a certain number of interrupt routines (or other routines) can perform page changes without reading and storing the previously used page information. The use of only write operations makes the system simpler and faster. Consequently, this mechanism significantly improves the performance of short interrupt routines.

The SAA-XC866 supports local address extension for:

- Parallel Ports
- Analog-to-Digital Converter (ADC)
- Capture/Compare Unit 6 (CCU6)
- System Control Registers

Functional Description

The page register has the following definition:

**MOD\_PAGE**

Page Register for module MOD

Reset Value: 00<sub>H</sub>

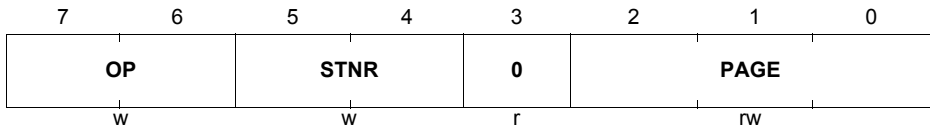

| Field       | Bits  | Type | Description   |
|-------------|-------|------|---|
| <b>PAGE</b> | [2:0] | rw   | <p><b>Page Bits</b></p> <p>When written, the value indicates the new page.<br/>When read, the value indicates the currently active page.</p>  |
| <b>STNR</b> | [5:4] | w    | <p><b>Storage Number</b></p> <p>This number indicates which storage bit field is the target of the operation defined by bit field OP.<br/>If OP = 10<sub>B</sub>,<br/>the contents of PAGE are saved in STx before being overwritten with the new value.<br/>If OP = 11<sub>B</sub>,<br/>the contents of PAGE are overwritten by the contents of STx. The value written to the bit positions of PAGE is ignored.</p> <p>00 ST0 is selected.<br/>01 ST1 is selected.<br/>10 ST2 is selected.<br/>11 ST3 is selected.</p> |

**Functional Description**

| Field     | Bits  | Type | Description   |
|-----------|-------|------|---|
| <b>OP</b> | [7:6] | w    | <p><b>Operation</b></p> <p>0X Manual page mode. The value of STNR is ignored and PAGE is directly written.</p> <p>10 New page programming with automatic page saving. The value written to the bit positions of PAGE is stored. In parallel, the previous contents of PAGE are saved in the storage bit field STx indicated by STNR.</p> <p>11 Automatic restore page action. The value written to the bit positions PAGE is ignored and instead, PAGE is overwritten by the contents of the storage bit field STx indicated by STNR.</p> |
| <b>0</b>  | 3     | r    | <p><b>Reserved</b><br/>Returns 0 if read; should be written with 0.</p>   |

Functional Description

### 3.2.3 Bit Protection Scheme

The bit protection scheme prevents direct software writing of selected bits (i.e., protected bits) using the PASSWD register. When the bit field MODE is 11<sub>B</sub>, writing 10011<sub>B</sub> to the bit field PASS opens access to writing of all protected bits, and writing 10101<sub>B</sub> to the bit field PASS closes access to writing of all protected bits. Note that access is opened for maximum 32 CCLKs if the “close access” password is not written. If “open access” password is written again before the end of 32 CCLK cycles, there will be a recount of 32 CCLK cycles. The protected bits include NDIV, WDTEN, PD, and SD.

#### PASSWD

#### Password Register

Reset Value: 07<sub>H</sub>

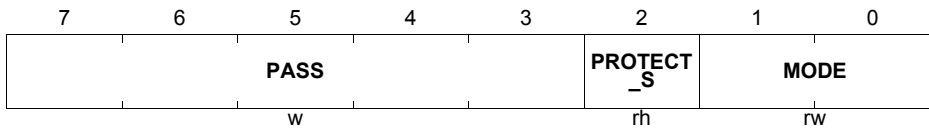

| Field            | Bits  | Type | Description  |
|------------------|-------|------|--|
| <b>MODE</b>      | [1:0] | rw   | <b>Bit Protection Scheme Control bits</b><br>00 Scheme Disabled<br>11 Scheme Enabled (default)<br>Others: Scheme Enabled<br>These two bits cannot be written directly. To change the value between 11 <sub>B</sub> and 00 <sub>B</sub> , the bit field PASS must be written with 11000 <sub>B</sub> ; only then, will the MODE[1:0] be registered. |
| <b>PROTECT_S</b> | 2     | rh   | <b>Bit Protection Signal Status bit</b><br>This bit shows the status of the protection.<br>0 Software is able to write to all protected bits.<br>1 Software is unable to write to any protected bits.  |
| <b>PASS</b>      | [7:3] | w    | <b>Password bits</b><br>The Bit Protection Scheme only recognizes three patterns.<br>11000 <sub>B</sub> Enables writing of the bit field MODE.<br>10011 <sub>B</sub> Opens access to writing of all protected bits.<br>10101 <sub>B</sub> Closes access to writing of all protected bits.  |

### 3.2.4 SAA-XC866 Register Overview

The SFRs of the SAA-XC866 are organized into groups according to their functional units. The contents (bits) of the SFRs are summarized in **Table 6** to **Table 14**, with the addresses of the bitaddressable SFRs appearing in bold typeface.

The CPU SFRs can be accessed in both the standard and mapped memory areas (RMAP = 0 or 1).

**Table 6 CPU Register Overview**

| Addr            | Register Name                                  | Bit                    | 7         | 6     | 5     | 4     | 3     | 2     | 1    | 0     |      |    |
|-----------------|--|------------------------|-----------|-------|-------|-------|-------|-------|------|-------|------|----|
| RMAP = 0 or 1   |  |                        |           |       |       |       |       |       |      |       |      |    |
| 81 <sub>H</sub> | <b>SP</b><br>Stack Pointer Register            | Reset: 07 <sub>H</sub> | Bit Field | SP    |       |       |       |       |      |       |      |    |
|                 |  |                        | Type      | rw    |       |       |       |       |      |       |      |    |
| 82 <sub>H</sub> | <b>DPL</b><br>Data Pointer Register Low        | Reset: 00 <sub>H</sub> | Bit Field | DPL7  | DPL6  | DPL5  | DPL4  | DPL3  | DPL2 | DPL1  | DPL0 |    |
|                 |  |                        | Type      | rw    | rw    | rw    | rw    | rw    | rw   | rw    | rw   | rw |
| 83 <sub>H</sub> | <b>DPH</b><br>Data Pointer Register High       | Reset: 00 <sub>H</sub> | Bit Field | DPH7  | DPH6  | DPH5  | DPH4  | DPH3  | DPH2 | DPH1  | DPH0 |    |
|                 |  |                        | Type      | rw    | rw    | rw    | rw    | rw    | rw   | rw    | rw   | rw |
| 87 <sub>H</sub> | <b>PCON</b><br>Power Control Register          | Reset: 00 <sub>H</sub> | Bit Field | SMOD  | 0     |       | GF1   |       | GF0  | 0     | IDLE |    |
|                 |  |                        | Type      | rw    | r     |       | rw    |       | rw   | r     | rw   |    |
| 88 <sub>H</sub> | <b>TCON</b><br>Timer Control Register          | Reset: 00 <sub>H</sub> | Bit Field | TF1   | TR1   | TF0   | TR0   | IE1   | IT1  | IE0   | IT0  |    |
|                 |  |                        | Type      | rwh   | rw    | rwh   | rw    | rwh   | rw   | rwh   | rw   |    |
| 89 <sub>H</sub> | <b>TMOD</b><br>Timer Mode Register             | Reset: 00 <sub>H</sub> | Bit Field | GATE1 | 0     | T1M   |       | GATE0 | 0    | T0M   |      |    |
|                 |  |                        | Type      | rw    | r     | rw    |       | rw    | r    | rw    |      |    |
| 8A <sub>H</sub> | <b>TL0</b><br>Timer 0 Register Low             | Reset: 00 <sub>H</sub> | Bit Field | VAL   |       |       |       |       |      |       |      |    |
|                 |  |                        | Type      | rwh   |       |       |       |       |      |       |      |    |
| 8B <sub>H</sub> | <b>TL1</b><br>Timer 1 Register Low             | Reset: 00 <sub>H</sub> | Bit Field | VAL   |       |       |       |       |      |       |      |    |
|                 |  |                        | Type      | rwh   |       |       |       |       |      |       |      |    |
| 8C <sub>H</sub> | <b>TH0</b><br>Timer 0 Register High            | Reset: 00 <sub>H</sub> | Bit Field | VAL   |       |       |       |       |      |       |      |    |
|                 |  |                        | Type      | rwh   |       |       |       |       |      |       |      |    |
| 8D <sub>H</sub> | <b>TH1</b><br>Timer 1 Register High            | Reset: 00 <sub>H</sub> | Bit Field | VAL   |       |       |       |       |      |       |      |    |
|                 |  |                        | Type      | rwh   |       |       |       |       |      |       |      |    |
| 98 <sub>H</sub> | <b>SCON</b><br>Serial Channel Control Register | Reset: 00 <sub>H</sub> | Bit Field | SM0   | SM1   | SM2   | REN   | TB8   | RB8  | TI    | RI   |    |
|                 |  |                        | Type      | rw    | rw    | rw    | rw    | rw    | rwh  | rwh   | rwh  |    |
| 99 <sub>H</sub> | <b>SBUF</b><br>Serial Data Buffer Register     | Reset: 00 <sub>H</sub> | Bit Field | VAL   |       |       |       |       |      |       |      |    |
|                 |  |                        | Type      | rwh   |       |       |       |       |      |       |      |    |
| A2 <sub>H</sub> | <b>EO</b><br>Extended Operation Register       | Reset: 00 <sub>H</sub> | Bit Field | 0     |       | TRAP_ |       | 0     |      | DPSEL |      |    |
|                 |  |                        | Type      | r     |       | rw    |       | r     |      | rw    |      |    |
| A8 <sub>H</sub> | <b>IEN0</b><br>Interrupt Enable Register 0     | Reset: 00 <sub>H</sub> | Bit Field | EA    | 0     | ET2   | ES    | ET1   | EX1  | ET0   | EX0  |    |
|                 |  |                        | Type      | rw    | r     | rw    | rw    | rw    | rw   | rw    | rw   |    |
| B8 <sub>H</sub> | <b>IP</b><br>Interrupt Priority Register       | Reset: 00 <sub>H</sub> | Bit Field | 0     |       | PT2   | PS    | PT1   | PX1  | PT0   | PX0  |    |
|                 |  |                        | Type      | r     |       | rw    | rw    | rw    | rw   | rw    | rw   |    |
| B9 <sub>H</sub> | <b>IPH</b><br>Interrupt Priority Register High | Reset: 00 <sub>H</sub> | Bit Field | 0     |       | PT2H  | PSH   | PT1H  | PX1H | PT0H  | PX0H |    |
|                 |  |                        | Type      | r     |       | rw    | rw    | rw    | rw   | rw    | rw   |    |
| D0 <sub>H</sub> | <b>PSW</b><br>Program Status Word Register     | Reset: 00 <sub>H</sub> | Bit Field | CY    | AC    | F0    | RS1   | RS0   | OV   | F1    | P    |    |
|                 |  |                        | Type      | rw    | rwh   | rwh   | rw    | rw    | rwh  | rwh   | rw   |    |
| E0 <sub>H</sub> | <b>ACC</b><br>Accumulator Register             | Reset: 00 <sub>H</sub> | Bit Field | ACC7  | ACC6  | ACC5  | ACC4  | ACC3  | ACC2 | ACC1  | ACC0 |    |
|                 |  |                        | Type      | rw    | rw    | rw    | rw    | rw    | rw   | rw    | rw   |    |
| E8 <sub>H</sub> | <b>IEN1</b><br>Interrupt Enable Register 1     | Reset: 00 <sub>H</sub> | Bit Field | ECCIP | ECCIP | ECCIP | ECCIP | EXM   | EX2  | ESSC  | EADC |    |
|                 |  |                        | Type      | rw    | rw    | rw    | rw    | rw    | rw   | rw    | rw   |    |

Functional Description

**Table 6 CPU Register Overview (cont'd)**

| Addr            | Register Name                                     | Reset:                 | Bit       | 7       | 6       | 5       | 4       | 3    | 2    | 1     | 0     |
|-----------------|---|------------------------|-----------|---------|---------|---------|---------|------|------|-------|-------|
| F0 <sub>H</sub> | <b>B</b><br>B Register                            | Reset: 00 <sub>H</sub> | Bit Field | B7      | B6      | B5      | B4      | B3   | B2   | B1    | B0    |
|                 |   |                        | Type      | rw      | rw      | rw      | rw      | rw   | rw   | rw    | rw    |
| F8 <sub>H</sub> | <b>IP1</b><br>Interrupt Priority Register 1       | Reset: 00 <sub>H</sub> | Bit Field | PCCIP3  | PCCIP2  | PCCIP1  | PCCIP0  | PXM  | PX2  | PSSC  | PADC  |
|                 |   |                        | Type      | rw      | rw      | rw      | rw      | rw   | rw   | rw    | rw    |
| F9 <sub>H</sub> | <b>IPH1</b><br>Interrupt Priority Register 1 High | Reset: 00 <sub>H</sub> | Bit Field | PCCIP3H | PCCIP2H | PCCIP1H | PCCIP0H | PXMH | PX2H | PSSCH | PADCH |
|                 |   |                        | Type      | rw      | rw      | rw      | rw      | rw   | rw   | rw    | rw    |

The system control SFRs can be accessed in the standard memory area (RMAP = 0).

**Table 7 System Control Register Overview**

| Addr             | Register Name   | Reset:                 | Bit       | 7        | 6        | 5         | 4         | 3         | 2          | 1         | 0        |
|------------------|---|------------------------|-----------|----------|----------|-----------|-----------|-----------|------------|-----------|----------|
| RMAP = 0 or 1    |   |                        |           |          |          |           |           |           |            |           |          |
| 8F <sub>H</sub>  | <b>SYSCON0</b><br>System Control Register 0             | Reset: 00 <sub>H</sub> | Bit Field | 0        |          |           |           |           |            |           | RMAP     |
|                  |   |                        | Type      | r        |          |           |           |           |            |           | rw       |
| RMAP = 0         |   |                        |           |          |          |           |           |           |            |           |          |
| BF <sub>H</sub>  | <b>SCU_PAGE</b><br>Page Register for System Control     | Reset: 00 <sub>H</sub> | Bit Field | OP       |          | STNR      |           | 0         | PAGE       |           |          |
|                  |   |                        | Type      | w        |          | w         |           | r         | rwh        |           |          |
| RMAP = 0, Page 0 |   |                        |           |          |          |           |           |           |            |           |          |
| B3 <sub>H</sub>  | <b>MODPISSEL</b><br>Peripheral Input Select Register    | Reset: 00 <sub>H</sub> | Bit Field | 0        |          | JTAG TDIS | JTAG TCKS | 0         |            | EXINT 0IS | URRIS    |
|                  |   |                        | Type      | r        |          | rw        | rw        | r         |            | rw        | rw       |
| B4 <sub>H</sub>  | <b>IRCON0</b><br>Interrupt Request Register 0           | Reset: 00 <sub>H</sub> | Bit Field | 0        | EXINT 6  | EXINT 5   | EXINT 4   | EXINT 3   | EXINT 2    | EXINT 1   | EXINT 0  |
|                  |   |                        | Type      | r        | rwh      | rwh       | rwh       | rwh       | rwh        | rwh       | rwh      |
| B5 <sub>H</sub>  | <b>IRCON1</b><br>Interrupt Request Register 1           | Reset: 00 <sub>H</sub> | Bit Field | 0        |          |           | ADCS RC1  | ADCS RC0  | RIR        | TIR       | EIR      |
|                  |   |                        | Type      | r        |          |           | rwh       | rwh       | rwh        | rwh       | rwh      |
| B7 <sub>H</sub>  | <b>EXICON0</b><br>External Interrupt Control Register 0 | Reset: 00 <sub>H</sub> | Bit Field | EXINT3   |          | EXINT2    |           | EXINT1    |            | EXINT0    |          |
|                  |   |                        | Type      | rw       |          | rw        |           | rw        |            | rw        |          |
| BA <sub>H</sub>  | <b>EXICON1</b><br>External Interrupt Control Register 1 | Reset: 00 <sub>H</sub> | Bit Field | 0        |          | EXINT6    |           | EXINT5    |            | EXINT4    |          |
|                  |   |                        | Type      | r        |          | rw        |           | rw        |            | rw        |          |
| BB <sub>H</sub>  | <b>NMICON</b><br>NMI Control Register                   | Reset: 00 <sub>H</sub> | Bit Field | 0        | NMI ECC  | NMI VDDP  | NMI VDD   | NMI OCDS  | NMI FLASH  | NMI PLL   | NMI WDT  |
|                  |   |                        | Type      | r        | rw       | rw        | rw        | rw        | rw         | rw        | rw       |
| BC <sub>H</sub>  | <b>NMISR</b><br>NMI Status Register                     | Reset: 00 <sub>H</sub> | Bit Field | 0        | FNMI ECC | FNMI VDDP | FNMI VDD  | FNMI OCDS | FNMI FLASH | FNMI PLL  | FNMI WDT |
|                  |   |                        | Type      | r        | rwh      | rwh       | rwh       | rwh       | rwh        | rwh       | rwh      |
| BD <sub>H</sub>  | <b>BCON</b><br>Baud Rate Control Register               | Reset: 00 <sub>H</sub> | Bit Field | BGSEL    |          | 0         | BREN      | BRPRE     |            |           | R        |
|                  |   |                        | Type      | rw       |          | r         | rw        | rw        |            |           | rw       |
| BE <sub>H</sub>  | <b>BG</b><br>Baud Rate Timer/Reload Register            | Reset: 00 <sub>H</sub> | Bit Field | BR_VALUE |          |           |           |           |            |           |          |
|                  |   |                        | Type      | rw       |          |           |           |           |            |           |          |
| E9 <sub>H</sub>  | <b>FDCON</b><br>Fractional Divider Control Register     | Reset: 00 <sub>H</sub> | Bit Field | BGS      | SYNEN    | ERRSYN    | E OFSYN   | BRK       | NDOV       | FDM       | FDEN     |
|                  |   |                        | Type      | rw       | rw       | rwh       | rwh       | rw        | rw         | rw        | rw       |
| EA <sub>H</sub>  | <b>FDSTEP</b><br>Fractional Divider Reload Register     | Reset: 00 <sub>H</sub> | Bit Field | STEP     |          |           |           |           |            |           |          |
|                  |   |                        | Type      | rw       |          |           |           |           |            |           |          |
| EB <sub>H</sub>  | <b>FDRES</b><br>Fractional Divider Result Register      | Reset: 00 <sub>H</sub> | Bit Field | RESULT   |          |           |           |           |            |           |          |
|                  |   |                        | Type      | rh       |          |           |           |           |            |           |          |
| RMAP = 0, Page 1 |   |                        |           |          |          |           |           |           |            |           |          |

**Functional Description**
**Table 7 System Control Register Overview (cont'd)**

| Addr             | Register Name  | Bit       | 7                | 6          | 5        | 4         | 3          | 2             | 1           | 0           |              |
|------------------|--|-----------|------------------|------------|----------|-----------|------------|---------------|-------------|-------------|--------------|
| B3 <sub>H</sub>  | <b>ID</b><br>Identity Register<br>Reset: 01 <sub>H</sub>                     | Bit Field | PRODID           |            |          |           |            |               | VERID       |             |              |
|                  |  | Type      | r                |            |          |           |            |               | r           |             |              |
| B4 <sub>H</sub>  | <b>PMCON0</b><br>Power Mode Control Register 0<br>Reset: 00 <sub>H</sub>     | Bit Field | 0                | WDT<br>RST | WKRS     | WK<br>SEL | SD         | PD            | WS          |             |              |
|                  |  | Type      | r                | rwh        | rwh      | rw        | rw         | rwh           | rw          |             |              |
| B5 <sub>H</sub>  | <b>PMCON1</b><br>Power Mode Control Register 1<br>Reset: 00 <sub>H</sub>     | Bit Field | 0                |            |          |           | T2_DIS     | CCU<br>_DIS   | SSC<br>_DIS | ADC<br>_DIS |              |
|                  |  | Type      | r                |            |          |           | rw         | rw            | rw          | rw          |              |
| B6 <sub>H</sub>  | <b>OSC_CON</b><br>OSC Control Register<br>Reset: 08 <sub>H</sub>             | Bit Field | 0                |            |          | OSC<br>PD | XPD        | OSC<br>SS     | ORD<br>RES  | OSCR        |              |
|                  |  | Type      | r                |            |          | rw        | rw         | rw            | rwh         | rh          |              |
| B7 <sub>H</sub>  | <b>PLL_CON</b><br>PLL Control Register<br>Reset: 20 <sub>H</sub>             | Bit Field | NDIV             |            |          |           | VCO<br>BYP | OSC<br>DISC   | RESLD       | LOCK        |              |
|                  |  | Type      | rw               |            |          |           | rw         | rw            | rwh         | rh          |              |
| BA <sub>H</sub>  | <b>CMCON</b><br>Clock Control Register<br>Reset: 00 <sub>H</sub>             | Bit Field | VCO<br>SEL       | 0          |          |           | CLKREL     |               |             |             |              |
|                  |  | Type      | rw               | r          |          |           | rw         |               |             |             |              |
| BB <sub>H</sub>  | <b>PASSWD</b><br>Password Register<br>Reset: 07 <sub>H</sub>                 | Bit Field | PASS             |            |          |           |            | PROTE<br>CT_S | MODE        |             |              |
|                  |  | Type      | w                |            |          |           |            | rh            | rw          |             |              |
| BC <sub>H</sub>  | <b>FEAL</b><br>Flash Error Address Register Low<br>Reset: 00 <sub>H</sub>    | Bit Field | ECCERRADDR[7:0]  |            |          |           |            |               |             |             |              |
|                  |  | Type      | rh               |            |          |           |            |               |             |             |              |
| BD <sub>H</sub>  | <b>FEAH</b><br>Flash Error Address Register High<br>Reset: 00 <sub>H</sub>   | Bit Field | ECCERRADDR[15:8] |            |          |           |            |               |             |             |              |
|                  |  | Type      | rh               |            |          |           |            |               |             |             |              |
| BE <sub>H</sub>  | <b>COCON</b><br>Clock Output Control Register<br>Reset: 00 <sub>H</sub>      | Bit Field | 0                | TLEN       | COU<br>S | COREL     |            |               |             |             |              |
|                  |  | Type      | r                | rw         | rw       | rw        |            |               |             |             |              |
| E9 <sub>H</sub>  | <b>MISC_CON</b><br>Miscellaneous Control Register<br>Reset: 00 <sub>H</sub>  | Bit Field | 0                |            |          |           |            |               |             |             | DFLAS<br>HEN |
|                  |  | Type      | r                |            |          |           |            |               |             |             | rwh          |
| RMAP = 0, Page 3 |  |           |                  |            |          |           |            |               |             |             |              |
| B3 <sub>H</sub>  | <b>XADDRH</b><br>On-Chip XRAM Address Higher Order<br>Reset: F0 <sub>H</sub> | Bit Field | ADDRH            |            |          |           |            |               |             |             |              |
|                  |  | Type      | rw               |            |          |           |            |               |             |             |              |

The WDT SFRs can be accessed in the mapped memory area (RMAP = 1).

**Table 8 WDT Register Overview**

| Addr            | Register Name  | Bit       | 7         | 6          | 5         | 4 | 3         | 2         | 1         | 0 |
|-----------------|--|-----------|-----------|------------|-----------|---|-----------|-----------|-----------|---|
| RMAP = 1        |  |           |           |            |           |   |           |           |           |   |
| BB <sub>H</sub> | <b>WDTCON</b><br>Watchdog Timer Control Register<br>Reset: 00 <sub>H</sub>             | Bit Field | 0         | WINB<br>EN | WDT<br>PR | 0 | WDT<br>EN | WDT<br>RS | WDT<br>IN |   |
|                 |  | Type      | r         | rw         | rh        | r | rw        | rwh       | rw        |   |
| BC <sub>H</sub> | <b>WDTREL</b><br>Watchdog Timer Reload Register<br>Reset: 00 <sub>H</sub>              | Bit Field | WDTREL    |            |           |   |           |           |           |   |
|                 |  | Type      | rw        |            |           |   |           |           |           |   |
| BD <sub>H</sub> | <b>WDTWINB</b><br>Watchdog Window-Boundary Count<br>Register<br>Reset: 00 <sub>H</sub> | Bit Field | WDTWINB   |            |           |   |           |           |           |   |
|                 |  | Type      | rw        |            |           |   |           |           |           |   |
| BE <sub>H</sub> | <b>WDTL</b><br>Watchdog Timer Register Low<br>Reset: 00 <sub>H</sub>                   | Bit Field | WDT[7:0]  |            |           |   |           |           |           |   |
|                 |  | Type      | rh        |            |           |   |           |           |           |   |
| BF <sub>H</sub> | <b>WDTH</b><br>Watchdog Timer Register High<br>Reset: 00 <sub>H</sub>                  | Bit Field | WDT[15:8] |            |           |   |           |           |           |   |
|                 |  | Type      | rh        |            |           |   |           |           |           |   |

**Functional Description**

The Port SFRs can be accessed in the standard memory area (RMAP = 0).

**Table 9 Port Register Overview**

| Addr             | Register Name  | Reset                        | Bit       | 7   | 6   | 5    | 4   | 3   | 2   | 1    | 0   |
|------------------|--|------------------------------|-----------|-----|-----|------|-----|-----|-----|------|-----|
| RMAP = 0         |  |                              |           |     |     |      |     |     |     |      |     |
| B2 <sub>H</sub>  | <b>PORT_PAGE</b><br>Page Register for PORT               | <b>Reset: 00<sub>H</sub></b> | Bit Field | OP  |     | STNR |     | 0   |     | PAGE |     |
|                  |  |                              | Type      | w   |     | w    |     | r   |     | rwh  |     |
| RMAP = 0, Page 0 |  |                              |           |     |     |      |     |     |     |      |     |
| 80 <sub>H</sub>  | <b>P0_DATA</b><br>P0 Data Register                       | <b>Reset: 00<sub>H</sub></b> | Bit Field | 0   | P5  | P4   | P3  | P2  | P1  | P0   |     |
|                  |  |                              | Type      | r   | rwh | rwh  | rwh | rwh | rwh | rwh  | rwh |
| 86 <sub>H</sub>  | <b>P0_DIR</b><br>P0 Direction Register                   | <b>Reset: 00<sub>H</sub></b> | Bit Field | 0   | P5  | P4   | P3  | P2  | P1  | P0   |     |
|                  |  |                              | Type      | r   | rw  | rw   | rw  | rw  | rw  | rw   | rw  |
| 90 <sub>H</sub>  | <b>P1_DATA</b><br>P1 Data Register                       | <b>Reset: 00<sub>H</sub></b> | Bit Field | P7  | P6  | P5   | 0   |     |     | P1   | P0  |
|                  |  |                              | Type      | rwh | rwh | rwh  | r   |     |     | rwh  | rwh |
| 91 <sub>H</sub>  | <b>P1_DIR</b><br>P1 Direction Register                   | <b>Reset: 00<sub>H</sub></b> | Bit Field | P7  | P6  | P5   | 0   |     |     | P1   | P0  |
|                  |  |                              | Type      | rw  | rw  | rw   | r   |     |     | rw   | rw  |
| A0 <sub>H</sub>  | <b>P2_DATA</b><br>P2 Data Register                       | <b>Reset: 00<sub>H</sub></b> | Bit Field | P7  | P6  | P5   | P4  | P3  | P2  | P1   | P0  |
|                  |  |                              | Type      | rwh | rwh | rwh  | rwh | rwh | rwh | rwh  | rwh |
| A1 <sub>H</sub>  | <b>P2_DIR</b><br>P2 Direction Register                   | <b>Reset: 00<sub>H</sub></b> | Bit Field | P7  | P6  | P5   | P4  | P3  | P2  | P1   | P0  |
|                  |  |                              | Type      | rw  | rw  | rw   | rw  | rw  | rw  | rw   | rw  |
| B0 <sub>H</sub>  | <b>P3_DATA</b><br>P3 Data Register                       | <b>Reset: 00<sub>H</sub></b> | Bit Field | P7  | P6  | P5   | P4  | P3  | P2  | P1   | P0  |
|                  |  |                              | Type      | rwh | rwh | rwh  | rwh | rwh | rwh | rwh  | rwh |
| B1 <sub>H</sub>  | <b>P3_DIR</b><br>P3 Direction Register                   | <b>Reset: 00<sub>H</sub></b> | Bit Field | P7  | P6  | P5   | P4  | P3  | P2  | P1   | P0  |
|                  |  |                              | Type      | rw  | rw  | rw   | rw  | rw  | rw  | rw   | rw  |
| RMAP = 0, Page 1 |  |                              |           |     |     |      |     |     |     |      |     |
| 80 <sub>H</sub>  | <b>P0_PUDSEL</b><br>P0 Pull-Up/Pull-Down Select Register | <b>Reset: FF<sub>H</sub></b> | Bit Field | 0   | P5  | P4   | P3  | P2  | P1  | P0   |     |
|                  |  |                              | Type      | r   | rw  | rw   | rw  | rw  | rw  | rw   | rw  |
| 86 <sub>H</sub>  | <b>P0_PUDEN</b><br>P0 Pull-Up/Pull-Down Enable Register  | <b>Reset: C4<sub>H</sub></b> | Bit Field | 0   | P5  | P4   | P3  | P2  | P1  | P0   |     |
|                  |  |                              | Type      | r   | rw  | rw   | rw  | rw  | rw  | rw   | rw  |
| 90 <sub>H</sub>  | <b>P1_PUDSEL</b><br>P1 Pull-Up/Pull-Down Select Register | <b>Reset: FF<sub>H</sub></b> | Bit Field | P7  | P6  | P5   | 0   |     |     | P1   | P0  |
|                  |  |                              | Type      | rw  | rw  | rw   | r   |     |     | rw   | rw  |
| 91 <sub>H</sub>  | <b>P1_PUDEN</b><br>P1 Pull-Up/Pull-Down Enable Register  | <b>Reset: FF<sub>H</sub></b> | Bit Field | P7  | P6  | P5   | 0   |     |     | P1   | P0  |
|                  |  |                              | Type      | rw  | rw  | rw   | r   |     |     | rw   | rw  |
| A0 <sub>H</sub>  | <b>P2_PUDSEL</b><br>P2 Pull-Up/Pull-Down Select Register | <b>Reset: FF<sub>H</sub></b> | Bit Field | P7  | P6  | P5   | P4  | P3  | P2  | P1   | P0  |
|                  |  |                              | Type      | rw  | rw  | rw   | rw  | rw  | rw  | rw   | rw  |
| A1 <sub>H</sub>  | <b>P2_PUDEN</b><br>P2 Pull-Up/Pull-Down Enable Register  | <b>Reset: 00<sub>H</sub></b> | Bit Field | P7  | P6  | P5   | P4  | P3  | P2  | P1   | P0  |
|                  |  |                              | Type      | rw  | rw  | rw   | rw  | rw  | rw  | rw   | rw  |
| B0 <sub>H</sub>  | <b>P3_PUDSEL</b><br>P3 Pull-Up/Pull-Down Select Register | <b>Reset: BF<sub>H</sub></b> | Bit Field | P7  | P6  | P5   | P4  | P3  | P2  | P1   | P0  |
|                  |  |                              | Type      | rw  | rw  | rw   | rw  | rw  | rw  | rw   | rw  |
| B1 <sub>H</sub>  | <b>P3_PUDEN</b><br>P3 Pull-Up/Pull-Down Enable Register  | <b>Reset: 40<sub>H</sub></b> | Bit Field | P7  | P6  | P5   | P4  | P3  | P2  | P1   | P0  |
|                  |  |                              | Type      | rw  | rw  | rw   | rw  | rw  | rw  | rw   | rw  |
| RMAP = 0, Page 2 |  |                              |           |     |     |      |     |     |     |      |     |
| 80 <sub>H</sub>  | <b>P0_ALTSEL0</b><br>P0 Alternate Select 0 Register      | <b>Reset: 00<sub>H</sub></b> | Bit Field | 0   | P5  | P4   | P3  | P2  | P1  | P0   |     |
|                  |  |                              | Type      | r   | rw  | rw   | rw  | rw  | rw  | rw   | rw  |
| 86 <sub>H</sub>  | <b>P0_ALTSEL1</b><br>P0 Alternate Select 1 Register      | <b>Reset: 00<sub>H</sub></b> | Bit Field | 0   | P5  | P4   | P3  | P2  | P1  | P0   |     |
|                  |  |                              | Type      | r   | rw  | rw   | rw  | rw  | rw  | rw   | rw  |
| 90 <sub>H</sub>  | <b>P1_ALTSEL0</b><br>P1 Alternate Select 0 Register      | <b>Reset: 00<sub>H</sub></b> | Bit Field | P7  | P6  | P5   | 0   |     |     | P1   | P0  |
|                  |  |                              | Type      | rw  | rw  | rw   | r   |     |     | rw   | rw  |
| 91 <sub>H</sub>  | <b>P1_ALTSEL1</b><br>P1 Alternate Select 1 Register      | <b>Reset: 00<sub>H</sub></b> | Bit Field | P7  | P6  | P5   | 0   |     |     | P1   | P0  |
|                  |  |                              | Type      | rw  | rw  | rw   | r   |     |     | rw   | rw  |
| B0 <sub>H</sub>  | <b>P3_ALTSEL0</b><br>P3 Alternate Select 0 Register      | <b>Reset: 00<sub>H</sub></b> | Bit Field | P7  | P6  | P5   | P4  | P3  | P2  | P1   | P0  |
|                  |  |                              | Type      | rw  | rw  | rw   | rw  | rw  | rw  | rw   | rw  |



**Functional Description**
**Table 9 Port Register Overview (cont'd)**

| Addr             | Register Name                                       | Reset:                 | Bit       | 7  | 6  | 5  | 4  | 3  | 2  | 1  | 0  |
|------------------|---|------------------------|-----------|----|----|----|----|----|----|----|----|
| B1 <sub>H</sub>  | <b>P3_ALTSEL1</b><br>P3 Alternate Select 1 Register | Reset: 00 <sub>H</sub> | Bit Field | P7 | P6 | P5 | P4 | P3 | P2 | P1 | P0 |
|                  |   |                        | Type      | rw | rw | rw | rw | rw | rw | rw | rw |
| RMAP = 0, Page 3 |   |                        |           |    |    |    |    |    |    |    |    |
| 80 <sub>H</sub>  | <b>P0_OD</b><br>P0 Open Drain Control Register      | Reset: 00 <sub>H</sub> | Bit Field | 0  |    | P5 | P4 | P3 | P2 | P1 | P0 |
|                  |   |                        | Type      | r  |    | rw | rw | rw | rw | rw | rw |
| 90 <sub>H</sub>  | <b>P1_OD</b><br>P1 Open Drain Control Register      | Reset: 00 <sub>H</sub> | Bit Field | P7 | P6 | P5 | 0  |    |    | P1 | P0 |
|                  |   |                        | Type      | rw | rw | rw | r  |    |    | rw | rw |
| B0 <sub>H</sub>  | <b>P3_OD</b><br>P3 Open Drain Control Register      | Reset: 00 <sub>H</sub> | Bit Field | P7 | P6 | P5 | P4 | P3 | P2 | P1 | P0 |
|                  |   |                        | Type      | rw | rw | rw | rw | rw | rw | rw | rw |

The ADC SFRs can be accessed in the standard memory area (RMAP = 0).

**Table 10 ADC Register Overview**

| Addr             | Register Name   | Reset:                 | Bit       | 7          | 6          | 5       | 4    | 3      | 2       | 1          | 0     |
|------------------|---|------------------------|-----------|------------|------------|---------|------|--------|---------|------------|-------|
| RMAP = 0         |   |                        |           |            |            |         |      |        |         |            |       |
| D1 <sub>H</sub>  | <b>ADC_PAGE</b><br>Page Register for ADC              | Reset: 00 <sub>H</sub> | Bit Field | OP         |            | STNR    |      | 0      | PAGE    |            |       |
|                  |   |                        | Type      | w          |            | w       |      | r      | rwh     |            |       |
| RMAP = 0, Page 0 |   |                        |           |            |            |         |      |        |         |            |       |
| CA <sub>H</sub>  | <b>ADC_GLOBCTR</b><br>Global Control Register         | Reset: 30 <sub>H</sub> | Bit Field | ANON       | DW         | CTC     |      | 0      |         |            |       |
|                  |   |                        | Type      | rw         | rw         | rw      |      | r      |         |            |       |
| CB <sub>H</sub>  | <b>ADC_GLOBSTR</b><br>Global Status Register          | Reset: 00 <sub>H</sub> | Bit Field | 0          |            | CHNR    |      |        | 0       | SAM<br>PLE | BUSY  |
|                  |   |                        | Type      | r          |            | rh      |      |        | r       | rh         | rh    |
| CC <sub>H</sub>  | <b>ADC_PRAR</b><br>Priority and Arbitration Register  | Reset: 00 <sub>H</sub> | Bit Field | ASEN1      | ASEN0      | 0       | ARBM | CSM1   | PRI01   | CSM0       | PRI00 |
|                  |   |                        | Type      | rw         | rw         | r       | rw   | rw     | rw      | rw         | rw    |
| CD <sub>H</sub>  | <b>ADC_LCBR</b><br>Limit Check Boundary Register      | Reset: B7 <sub>H</sub> | Bit Field | BOUND1     |            |         |      | BOUND0 |         |            |       |
|                  |   |                        | Type      | rw         |            |         |      | rw     |         |            |       |
| CE <sub>H</sub>  | <b>ADC_INPCR0</b><br>Input Class Register 0           | Reset: 00 <sub>H</sub> | Bit Field | STC        |            |         |      |        |         |            |       |
|                  |   |                        | Type      | rw         |            |         |      |        |         |            |       |
| CF <sub>H</sub>  | <b>ADC_ETRCR</b><br>External Trigger Control Register | Reset: 00 <sub>H</sub> | Bit Field | SYNEN<br>1 | SYNEN<br>0 | ETRSEL1 |      |        | ETRSEL0 |            |       |
|                  |   |                        | Type      | rw         | rw         | rw      |      |        | rw      |            |       |
| RMAP = 0, Page 1 |   |                        |           |            |            |         |      |        |         |            |       |
| CA <sub>H</sub>  | <b>ADC_CHCTR0</b><br>Channel Control Register 0       | Reset: 00 <sub>H</sub> | Bit Field | 0          | LCC        |         |      | 0      | RESRSEL |            |       |
|                  |   |                        | Type      | r          | rw         |         |      | r      | rw      |            |       |
| CB <sub>H</sub>  | <b>ADC_CHCTR1</b><br>Channel Control Register 1       | Reset: 00 <sub>H</sub> | Bit Field | 0          | LCC        |         |      | 0      | RESRSEL |            |       |
|                  |   |                        | Type      | r          | rw         |         |      | r      | rw      |            |       |
| CC <sub>H</sub>  | <b>ADC_CHCTR2</b><br>Channel Control Register 2       | Reset: 00 <sub>H</sub> | Bit Field | 0          | LCC        |         |      | 0      | RESRSEL |            |       |
|                  |   |                        | Type      | r          | rw         |         |      | r      | rw      |            |       |
| CD <sub>H</sub>  | <b>ADC_CHCTR3</b><br>Channel Control Register 3       | Reset: 00 <sub>H</sub> | Bit Field | 0          | LCC        |         |      | 0      | RESRSEL |            |       |
|                  |   |                        | Type      | r          | rw         |         |      | r      | rw      |            |       |
| CE <sub>H</sub>  | <b>ADC_CHCTR4</b><br>Channel Control Register 4       | Reset: 00 <sub>H</sub> | Bit Field | 0          | LCC        |         |      | 0      | RESRSEL |            |       |
|                  |   |                        | Type      | r          | rw         |         |      | r      | rw      |            |       |
| CF <sub>H</sub>  | <b>ADC_CHCTR5</b><br>Channel Control Register 5       | Reset: 00 <sub>H</sub> | Bit Field | 0          | LCC        |         |      | 0      | RESRSEL |            |       |
|                  |   |                        | Type      | r          | rw         |         |      | r      | rw      |            |       |
| D2 <sub>H</sub>  | <b>ADC_CHCTR6</b><br>Channel Control Register 6       | Reset: 00 <sub>H</sub> | Bit Field | 0          | LCC        |         |      | 0      | RESRSEL |            |       |
|                  |   |                        | Type      | r          | rw         |         |      | r      | rw      |            |       |
| D3 <sub>H</sub>  | <b>ADC_CHCTR7</b><br>Channel Control Register 7       | Reset: 00 <sub>H</sub> | Bit Field | 0          | LCC        |         |      | 0      | RESRSEL |            |       |
|                  |   |                        | Type      | r          | rw         |         |      | r      | rw      |            |       |
| RMAP = 0, Page 2 |   |                        |           |            |            |         |      |        |         |            |       |

**Functional Description**
**Table 10 ADC Register Overview (cont'd)**

| Addr             | Register Name  | Bit                    | 7         | 6            | 5   | 4  | 3    | 2    | 1    | 0    |   |
|------------------|--|------------------------|-----------|--------------|-----|----|------|------|------|------|---|
| CA <sub>H</sub>  | <b>ADC_RESR0L</b><br>Result Register 0 Low           | Reset: 00 <sub>H</sub> | Bit Field | RESULT[1:0]  |     | 0  | VF   | DRC  | CHNR |      |   |
|                  |  |                        | Type      | rh           |     | r  | rh   | rh   | rh   |      |   |
| CB <sub>H</sub>  | <b>ADC_RESR0H</b><br>Result Register 0 High          | Reset: 00 <sub>H</sub> | Bit Field | RESULT[9:2]  |     |    |      |      |      |      |   |
|                  |  |                        | Type      | rh           |     |    |      |      |      |      |   |
| CC <sub>H</sub>  | <b>ADC_RESR1L</b><br>Result Register 1 Low           | Reset: 00 <sub>H</sub> | Bit Field | RESULT[1:0]  |     | 0  | VF   | DRC  | CHNR |      |   |
|                  |  |                        | Type      | rh           |     | r  | rh   | rh   | rh   |      |   |
| CD <sub>H</sub>  | <b>ADC_RESR1H</b><br>Result Register 1 High          | Reset: 00 <sub>H</sub> | Bit Field | RESULT[9:2]  |     |    |      |      |      |      |   |
|                  |  |                        | Type      | rh           |     |    |      |      |      |      |   |
| CE <sub>H</sub>  | <b>ADC_RESR2L</b><br>Result Register 2 Low           | Reset: 00 <sub>H</sub> | Bit Field | RESULT[1:0]  |     | 0  | VF   | DRC  | CHNR |      |   |
|                  |  |                        | Type      | rh           |     | r  | rh   | rh   | rh   |      |   |
| CF <sub>H</sub>  | <b>ADC_RESR2H</b><br>Result Register 2 High          | Reset: 00 <sub>H</sub> | Bit Field | RESULT[9:2]  |     |    |      |      |      |      |   |
|                  |  |                        | Type      | rh           |     |    |      |      |      |      |   |
| D2 <sub>H</sub>  | <b>ADC_RESR3L</b><br>Result Register 3 Low           | Reset: 00 <sub>H</sub> | Bit Field | RESULT[1:0]  |     | 0  | VF   | DRC  | CHNR |      |   |
|                  |  |                        | Type      | rh           |     | r  | rh   | rh   | rh   |      |   |
| D3 <sub>H</sub>  | <b>ADC_RESR3H</b><br>Result Register 3 High          | Reset: 00 <sub>H</sub> | Bit Field | RESULT[9:2]  |     |    |      |      |      |      |   |
|                  |  |                        | Type      | rh           |     |    |      |      |      |      |   |
| RMAP = 0, Page 3 |  |                        |           |              |     |    |      |      |      |      |   |
| CA <sub>H</sub>  | <b>ADC_RESRA0L</b><br>Result Register 0, View A Low  | Reset: 00 <sub>H</sub> | Bit Field | RESULT[2:0]  |     | VF | DRC  | CHNR |      |      |   |
|                  |  |                        | Type      | rh           |     | rh | rh   | rh   |      |      |   |
| CB <sub>H</sub>  | <b>ADC_RESRA0H</b><br>Result Register 0, View A High | Reset: 00 <sub>H</sub> | Bit Field | RESULT[10:3] |     |    |      |      |      |      |   |
|                  |  |                        | Type      | rh           |     |    |      |      |      |      |   |
| CC <sub>H</sub>  | <b>ADC_RESRA1L</b><br>Result Register 1, View A Low  | Reset: 00 <sub>H</sub> | Bit Field | RESULT[2:0]  |     | VF | DRC  | CHNR |      |      |   |
|                  |  |                        | Type      | rh           |     | rh | rh   | rh   |      |      |   |
| CD <sub>H</sub>  | <b>ADC_RESRA1H</b><br>Result Register 1, View A High | Reset: 00 <sub>H</sub> | Bit Field | RESULT[10:3] |     |    |      |      |      |      |   |
|                  |  |                        | Type      | rh           |     |    |      |      |      |      |   |
| CE <sub>H</sub>  | <b>ADC_RESRA2L</b><br>Result Register 2, View A Low  | Reset: 00 <sub>H</sub> | Bit Field | RESULT[2:0]  |     | VF | DRC  | CHNR |      |      |   |
|                  |  |                        | Type      | rh           |     | rh | rh   | rh   |      |      |   |
| CF <sub>H</sub>  | <b>ADC_RESRA2H</b><br>Result Register 2, View A High | Reset: 00 <sub>H</sub> | Bit Field | RESULT[10:3] |     |    |      |      |      |      |   |
|                  |  |                        | Type      | rh           |     |    |      |      |      |      |   |
| D2 <sub>H</sub>  | <b>ADC_RESRA3L</b><br>Result Register 3, View A Low  | Reset: 00 <sub>H</sub> | Bit Field | RESULT[2:0]  |     | VF | DRC  | CHNR |      |      |   |
|                  |  |                        | Type      | rh           |     | rh | rh   | rh   |      |      |   |
| D3 <sub>H</sub>  | <b>ADC_RESRA3H</b><br>Result Register 3, View A High | Reset: 00 <sub>H</sub> | Bit Field | RESULT[10:3] |     |    |      |      |      |      |   |
|                  |  |                        | Type      | rh           |     |    |      |      |      |      |   |
| RMAP = 0, Page 4 |  |                        |           |              |     |    |      |      |      |      |   |
| CA <sub>H</sub>  | <b>ADC_RCR0</b><br>Result Control Register 0         | Reset: 00 <sub>H</sub> | Bit Field | VFCTR        | WFR | 0  | IEN  | 0    |      | DRCT | R |
|                  |  |                        | Type      | rw           | rw  | r  | rw   | r    |      | rw   |   |
| CB <sub>H</sub>  | <b>ADC_RCR1</b><br>Result Control Register 1         | Reset: 00 <sub>H</sub> | Bit Field | VFCTR        | WFR | 0  | IEN  | 0    |      | DRCT | R |
|                  |  |                        | Type      | rw           | rw  | r  | rw   | r    |      | rw   |   |
| CC <sub>H</sub>  | <b>ADC_RCR2</b><br>Result Control Register 2         | Reset: 00 <sub>H</sub> | Bit Field | VFCTR        | WFR | 0  | IEN  | 0    |      | DRCT | R |
|                  |  |                        | Type      | rw           | rw  | r  | rw   | r    |      | rw   |   |
| CD <sub>H</sub>  | <b>ADC_RCR3</b><br>Result Control Register 3         | Reset: 00 <sub>H</sub> | Bit Field | VFCTR        | WFR | 0  | IEN  | 0    |      | DRCT | R |
|                  |  |                        | Type      | rw           | rw  | r  | rw   | r    |      | rw   |   |
| CE <sub>H</sub>  | <b>ADC_VFCR</b><br>Valid Flag Clear Register         | Reset: 00 <sub>H</sub> | Bit Field | 0            |     |    | VFC3 | VFC2 | VFC1 | VFC0 |   |
|                  |  |                        | Type      | r            |     |    | w    | w    | w    | w    |   |
| RMAP = 0, Page 5 |  |                        |           |              |     |    |      |      |      |      |   |

**Functional Description**
**Table 10 ADC Register Overview (cont'd)**

| Addr             | Register Name   | Bit       | 7          | 6          | 5          | 4          | 3          | 2          | 1          | 0          |
|------------------|---|-----------|------------|------------|------------|------------|------------|------------|------------|------------|
| CA <sub>H</sub>  | <b>ADC_CHINFR</b> <b>Reset: 00<sub>H</sub></b><br>Channel Interrupt Flag Register         | Bit Field | CHINF<br>7 | CHINF<br>6 | CHINF<br>5 | CHINF<br>4 | CHINF<br>3 | CHINF<br>2 | CHINF<br>1 | CHINF<br>0 |
|                  |   | Type      | rh         | rh         | rh         | rh         | rh         | rh         | rh         | rh         |
| CB <sub>H</sub>  | <b>ADC_CHINCR</b> <b>Reset: 00<sub>H</sub></b><br>Channel Interrupt Clear Register        | Bit Field | CHINC<br>7 | CHINC<br>6 | CHINC<br>5 | CHINC<br>4 | CHINC<br>3 | CHINC<br>2 | CHINC<br>1 | CHINC<br>0 |
|                  |   | Type      | w          | w          | w          | w          | w          | w          | w          | w          |
| CC <sub>H</sub>  | <b>ADC_CHINSR</b> <b>Reset: 00<sub>H</sub></b><br>Channel Interrupt Set Register          | Bit Field | CHINS<br>7 | CHINS<br>6 | CHINS<br>5 | CHINS<br>4 | CHINS<br>3 | CHINS<br>2 | CHINS<br>1 | CHINS<br>0 |
|                  |   | Type      | w          | w          | w          | w          | w          | w          | w          | w          |
| CD <sub>H</sub>  | <b>ADC_CHINPR</b> <b>Reset: 00<sub>H</sub></b><br>Channel Interrupt Node Pointer Register | Bit Field | CHINP<br>7 | CHINP<br>6 | CHINP<br>5 | CHINP<br>4 | CHINP<br>3 | CHINP<br>2 | CHINP<br>1 | CHINP<br>0 |
|                  |   | Type      | rw         | rw         | rw         | rw         | rw         | rw         | rw         | rw         |
| CE <sub>H</sub>  | <b>ADC_EVINFR</b> <b>Reset: 00<sub>H</sub></b><br>Event Interrupt Flag Register           | Bit Field | EVINF<br>7 | EVINF<br>6 | EVINF<br>5 | EVINF<br>4 | 0          |            | EVINF<br>1 | EVINF<br>0 |
|                  |   | Type      | rh         | rh         | rh         | rh         | r          |            | rh         | rh         |
| CF <sub>H</sub>  | <b>ADC_EVINCR</b> <b>Reset: 00<sub>H</sub></b><br>Event Interrupt Clear Flag Register     | Bit Field | EVINC<br>7 | EVINC<br>6 | EVINC<br>5 | EVINC<br>4 | 0          |            | EVINC<br>1 | EVINC<br>0 |
|                  |   | Type      | w          | w          | w          | w          | r          |            | w          | w          |
| D2 <sub>H</sub>  | <b>ADC_EVINSR</b> <b>Reset: 00<sub>H</sub></b><br>Event Interrupt Set Flag Register       | Bit Field | EVINS<br>7 | EVINS<br>6 | EVINS<br>5 | EVINS<br>4 | 0          |            | EVINS<br>1 | EVINS<br>0 |
|                  |   | Type      | w          | w          | w          | w          | r          |            | w          | w          |
| D3 <sub>H</sub>  | <b>ADC_EVINPR</b> <b>Reset: 00<sub>H</sub></b><br>Event Interrupt Node Pointer Register   | Bit Field | EVINP<br>7 | EVINP<br>6 | EVINP<br>5 | EVINP<br>4 | 0          |            | EVINP<br>1 | EVINP<br>0 |
|                  |   | Type      | rw         | rw         | rw         | rw         | r          |            | rw         | rw         |
| RMAP = 0, Page 6 |   |           |            |            |            |            |            |            |            |            |
| CA <sub>H</sub>  | <b>ADC_CRCR1</b> <b>Reset: 00<sub>H</sub></b><br>Conversion Request Control Register 1    | Bit Field | CH7        | CH6        | CH5        | CH4        | 0          |            |            |            |
|                  |   | Type      | rwh        | rwh        | rwh        | rwh        | r          |            |            |            |
| CB <sub>H</sub>  | <b>ADC_CRPR1</b> <b>Reset: 00<sub>H</sub></b><br>Conversion Request Pending Register 1    | Bit Field | CHP7       | CHP6       | CHP5       | CHP4       | 0          |            |            |            |
|                  |   | Type      | rwh        | rwh        | rwh        | rwh        | r          |            |            |            |
| CC <sub>H</sub>  | <b>ADC_CRMR1</b> <b>Reset: 00<sub>H</sub></b><br>Conversion Request Mode Register 1       | Bit Field | Rsv        | LDEV       | CLR<br>PND | SCAN       | ENSI       | ENTR       | ENGT       |            |
|                  |   | Type      | r          | w          | w          | rw         | rw         | rw         | rw         |            |
| CD <sub>H</sub>  | <b>ADC_QMR0</b> <b>Reset: 00<sub>H</sub></b><br>Queue Mode Register 0                     | Bit Field | CEV        | TREV       | FLUSH      | CLRV       | TRMD       | ENTR       | ENGT       |            |
|                  |   | Type      | w          | w          | w          | w          | rw         | rw         | rw         |            |
| CE <sub>H</sub>  | <b>ADC_QSR0</b> <b>Reset: 20<sub>H</sub></b><br>Queue Status Register 0                   | Bit Field | Rsv        | 0          | EMPTY      | EV         | 0          |            |            |            |
|                  |   | Type      | r          | r          | rh         | rh         | r          |            |            |            |
| CF <sub>H</sub>  | <b>ADC_Q0R0</b> <b>Reset: 00<sub>H</sub></b><br>Queue 0 Register 0                        | Bit Field | EXTR       | ENSI       | RF         | V          | 0          | REQCHNR    |            |            |
|                  |   | Type      | rh         | rh         | rh         | rh         | r          | rh         |            |            |
| D2 <sub>H</sub>  | <b>ADC_QBUR0</b> <b>Reset: 00<sub>H</sub></b><br>Queue Backup Register 0                  | Bit Field | EXTR       | ENSI       | RF         | V          | 0          | REQCHNR    |            |            |
|                  |   | Type      | rh         | rh         | rh         | rh         | r          | rh         |            |            |
| D2 <sub>H</sub>  | <b>ADC_QINR0</b> <b>Reset: 00<sub>H</sub></b><br>Queue Input Register 0                   | Bit Field | EXTR       | ENSI       | RF         | 0          |            | REQCHNR    |            |            |
|                  |   | Type      | w          | w          | w          | r          |            | w          |            |            |

The Timer 2 SFRs can be accessed in the standard memory area (RMAP = 0).

**Table 11 Timer 2 Register Overview**

| Addr            | Register Name  | Bit       | 7   | 6    | 5 | 4 | 3     | 2   | 1 | 0          |
|-----------------|--|-----------|-----|------|---|---|-------|-----|---|------------|
| C0 <sub>H</sub> | <b>T2_T2CON</b> <b>Reset: 00<sub>H</sub></b><br>Timer 2 Control Register | Bit Field | TF2 | EXF2 | 0 |   | EXEN2 | TR2 | 0 | CP/<br>RL2 |
|                 |  | Type      | rwh | rwh  | r |   | rw    | rwh | r | rw         |

**Functional Description**
**Table 11 Timer 2 Register Overview (cont'd)**

| C1 <sub>H</sub> | <b>T2_T2MOD</b><br>Timer 2 Mode Register               | <b>Reset: 00<sub>H</sub></b> | Bit Field | T2<br>REGS | T2<br>RHEN | EDGE<br>SEL | PREN | T2PRE | DCEN |
|-----------------|--|------------------------------|-----------|------------|------------|-------------|------|-------|------|
|                 |  |                              | Type      | rw         | rw         | rw          | rw   | rw    | rw   |
| C2 <sub>H</sub> | <b>T2_RC2L</b><br>Timer 2 Reload/Capture Register Low  | <b>Reset: 00<sub>H</sub></b> | Bit Field | RC2[7:0]   |            |             |      |       |      |
|                 |  |                              | Type      | rwh        |            |             |      |       |      |
| C3 <sub>H</sub> | <b>T2_RC2H</b><br>Timer 2 Reload/Capture Register High | <b>Reset: 00<sub>H</sub></b> | Bit Field | RC2[15:8]  |            |             |      |       |      |
|                 |  |                              | Type      | rwh        |            |             |      |       |      |
| C4 <sub>H</sub> | <b>T2_T2L</b><br>Timer 2 Register Low                  | <b>Reset: 00<sub>H</sub></b> | Bit Field | THL2[7:0]  |            |             |      |       |      |
|                 |  |                              | Type      | rwh        |            |             |      |       |      |
| C5 <sub>H</sub> | <b>T2_T2H</b><br>Timer 2 Register High                 | <b>Reset: 00<sub>H</sub></b> | Bit Field | THL2[15:8] |            |             |      |       |      |
|                 |  |                              | Type      | rwh        |            |             |      |       |      |

The CCU6 SFRs can be accessed in the standard memory area (RMAP = 0).

**Table 12 CCU6 Register Overview**

| Addr             | Register Name  | Bit                          | 7         | 6          | 5          | 4          | 3          | 2          | 1          | 0          |            |
|------------------|--|------------------------------|-----------|------------|------------|------------|------------|------------|------------|------------|------------|
| RMAP = 0         |  |                              |           |            |            |            |            |            |            |            |            |
| A3 <sub>H</sub>  | <b>CCU6_PAGE</b><br>Page Register for CCU6                                   | <b>Reset: 00<sub>H</sub></b> | Bit Field | OP         |            | STNR       |            | 0          | PAGE       |            |            |
|                  |  |                              | Type      | w          |            | w          |            | r          | rwh        |            |            |
| RMAP = 0, Page 0 |  |                              |           |            |            |            |            |            |            |            |            |
| 9A <sub>H</sub>  | <b>CCU6_CC63SRL</b><br>Capture/Compare Shadow Register for Channel CC63 Low  | <b>Reset: 00<sub>H</sub></b> | Bit Field | CC63SL     |            |            |            |            |            |            |            |
|                  |  |                              | Type      | rw         |            |            |            |            |            |            |            |
| 9B <sub>H</sub>  | <b>CCU6_CC63SRH</b><br>Capture/Compare Shadow Register for Channel CC63 High | <b>Reset: 00<sub>H</sub></b> | Bit Field | CC63SH     |            |            |            |            |            |            |            |
|                  |  |                              | Type      | rw         |            |            |            |            |            |            |            |
| 9C <sub>H</sub>  | <b>CCU6_TCTR4L</b><br>Timer Control Register 4 Low                           | <b>Reset: 00<sub>H</sub></b> | Bit Field | T12<br>STD | T12<br>STR | 0          |            | DTRES      | T12<br>RES | T12RS      | T12RR      |
|                  |  |                              | Type      | w          | w          | r          |            | w          | w          | w          | w          |
| 9D <sub>H</sub>  | <b>CCU6_TCTR4H</b><br>Timer Control Register 4 High                          | <b>Reset: 00<sub>H</sub></b> | Bit Field | T13<br>STD | T13<br>STR | 0          |            | T13<br>RES | T13RS      | T13RR      |            |
|                  |  |                              | Type      | w          | w          | r          |            | w          | w          | w          |            |
| 9E <sub>H</sub>  | <b>CCU6_MCMOUTSL</b><br>Multi-Channel Mode Output Shadow Register Low        | <b>Reset: 00<sub>H</sub></b> | Bit Field | STRM<br>CM | 0          | MCMPS      |            |            |            |            |            |
|                  |  |                              | Type      | w          | r          | rw         |            |            |            |            |            |
| 9F <sub>H</sub>  | <b>CCU6_MCMOUTSH</b><br>Multi-Channel Mode Output Shadow Register High       | <b>Reset: 00<sub>H</sub></b> | Bit Field | STRHP      | 0          | CURHS      |            |            | EXPHS      |            |            |
|                  |  |                              | Type      | w          | r          | rw         |            |            | rw         |            |            |
| A4 <sub>H</sub>  | <b>CCU6_ISR_L</b><br>Capture/Compare Interrupt Status Reset Register Low     | <b>Reset: 00<sub>H</sub></b> | Bit Field | RT12P<br>M | RT12O<br>M | RCC62<br>F | RCC62<br>R | RCC61<br>F | RCC61<br>R | RCC60<br>F | RCC60<br>R |
|                  |  |                              | Type      | w          | w          | w          | w          | w          | w          | w          | w          |
| A5 <sub>H</sub>  | <b>CCU6_ISR_H</b><br>Capture/Compare Interrupt Status Reset Register High    | <b>Reset: 00<sub>H</sub></b> | Bit Field | RSTR       | RIDLE      | RWHE       | RCHE       | 0          | RTRPF      | RT13<br>PM | RT13<br>CM |
|                  |  |                              | Type      | w          | w          | w          | w          | r          | w          | w          | w          |
| A6 <sub>H</sub>  | <b>CCU6_CMPMODIFL</b><br>Compare State Modification Register Low             | <b>Reset: 00<sub>H</sub></b> | Bit Field | 0          | MCC63<br>S | 0          |            | MCC62<br>S | MCC61<br>S | MCC60<br>S |            |
|                  |  |                              | Type      | r          | w          | r          |            | w          | w          | w          |            |
| A7 <sub>H</sub>  | <b>CCU6_CMPMODIFH</b><br>Compare State Modification Register High            | <b>Reset: 00<sub>H</sub></b> | Bit Field | 0          | MCC63<br>R | 0          |            | MCC62<br>R | MCC61<br>R | MCC60<br>R |            |
|                  |  |                              | Type      | r          | w          | r          |            | w          | w          | w          |            |
| FA <sub>H</sub>  | <b>CCU6_CC60SRL</b><br>Capture/Compare Shadow Register for Channel CC60 Low  | <b>Reset: 00<sub>H</sub></b> | Bit Field | CC60SL     |            |            |            |            |            |            |            |
|                  |  |                              | Type      | rwh        |            |            |            |            |            |            |            |

**Functional Description**
**Table 12 CCU6 Register Overview (cont'd)**

| Addr             | Register Name   | Bit       | 7      | 6    | 5     | 4    | 3       | 2      | 1    | 0    |
|------------------|---|-----------|--------|------|-------|------|---------|--------|------|------|
| FB <sub>H</sub>  | <b>CCU6_CC60SRH</b> <b>Reset: 00<sub>H</sub></b><br>Capture/Compare Shadow Register for Channel CC60 High | Bit Field | CC60SH |      |       |      |         |        |      |      |
|                  |   | Type      | rwh    |      |       |      |         |        |      |      |
| FC <sub>H</sub>  | <b>CCU6_CC61SRL</b> <b>Reset: 00<sub>H</sub></b><br>Capture/Compare Shadow Register for Channel CC61 Low  | Bit Field | CC61SL |      |       |      |         |        |      |      |
|                  |   | Type      | rwh    |      |       |      |         |        |      |      |
| FD <sub>H</sub>  | <b>CCU6_CC61SRH</b> <b>Reset: 00<sub>H</sub></b><br>Capture/Compare Shadow Register for Channel CC61 High | Bit Field | CC61SH |      |       |      |         |        |      |      |
|                  |   | Type      | rwh    |      |       |      |         |        |      |      |
| FE <sub>H</sub>  | <b>CCU6_CC62SRL</b> <b>Reset: 00<sub>H</sub></b><br>Capture/Compare Shadow Register for Channel CC62 Low  | Bit Field | CC62SL |      |       |      |         |        |      |      |
|                  |   | Type      | rwh    |      |       |      |         |        |      |      |
| FF <sub>H</sub>  | <b>CCU6_CC62SRH</b> <b>Reset: 00<sub>H</sub></b><br>Capture/Compare Shadow Register for Channel CC62 High | Bit Field | CC62SH |      |       |      |         |        |      |      |
|                  |   | Type      | rwh    |      |       |      |         |        |      |      |
| RMAP = 0, Page 1 |   |           |        |      |       |      |         |        |      |      |
| 9A <sub>H</sub>  | <b>CCU6_CC63RL</b> <b>Reset: 00<sub>H</sub></b><br>Capture/Compare Register for Channel CC63 Low          | Bit Field | CC63VL |      |       |      |         |        |      |      |
|                  |   | Type      | rh     |      |       |      |         |        |      |      |
| 9B <sub>H</sub>  | <b>CCU6_CC63RH</b> <b>Reset: 00<sub>H</sub></b><br>Capture/Compare Register for Channel CC63 High         | Bit Field | CC63VH |      |       |      |         |        |      |      |
|                  |   | Type      | rh     |      |       |      |         |        |      |      |
| 9C <sub>H</sub>  | <b>CCU6_T12PRL</b> <b>Reset: 00<sub>H</sub></b><br>Timer T12 Period Register Low                          | Bit Field | T12PVL |      |       |      |         |        |      |      |
|                  |   | Type      | rwh    |      |       |      |         |        |      |      |
| 9D <sub>H</sub>  | <b>CCU6_T12PRH</b> <b>Reset: 00<sub>H</sub></b><br>Timer T12 Period Register High                         | Bit Field | T12PVH |      |       |      |         |        |      |      |
|                  |   | Type      | rwh    |      |       |      |         |        |      |      |
| 9E <sub>H</sub>  | <b>CCU6_T13PRL</b> <b>Reset: 00<sub>H</sub></b><br>Timer T13 Period Register Low                          | Bit Field | T13PVL |      |       |      |         |        |      |      |
|                  |   | Type      | rwh    |      |       |      |         |        |      |      |
| 9F <sub>H</sub>  | <b>CCU6_T13PRH</b> <b>Reset: 00<sub>H</sub></b><br>Timer T13 Period Register High                         | Bit Field | T13PVH |      |       |      |         |        |      |      |
|                  |   | Type      | rwh    |      |       |      |         |        |      |      |
| A4 <sub>H</sub>  | <b>CCU6_T12DTCL</b> <b>Reset: 00<sub>H</sub></b><br>Dead-Time Control Register for Timer T12 Low          | Bit Field | DTM    |      |       |      |         |        |      |      |
|                  |   | Type      | rw     |      |       |      |         |        |      |      |
| A5 <sub>H</sub>  | <b>CCU6_T12DTCH</b> <b>Reset: 00<sub>H</sub></b><br>Dead-Time Control Register for Timer T12 High         | Bit Field | 0      | DTR2 | DTR1  | DTR0 | 0       | DTE2   | DTE1 | DTE0 |
|                  |   | Type      | r      | rh   | rh    | rh   | r       | rw     | rw   | rw   |
| A6 <sub>H</sub>  | <b>CCU6_TCTR0L</b> <b>Reset: 00<sub>H</sub></b><br>Timer Control Register 0 Low                           | Bit Field | CTM    | CDIR | STE12 | T12R | T12 PRE | T12CLK |      |      |
|                  |   | Type      | rw     | rh   | rh    | rh   | rw      | rw     |      |      |
| A7 <sub>H</sub>  | <b>CCU6_TCTR0H</b> <b>Reset: 00<sub>H</sub></b><br>Timer Control Register 0 High                          | Bit Field | 0      |      | STE13 | T13R | T13 PRE | T13CLK |      |      |
|                  |   | Type      | r      |      | rh    | rh   | rw      | rw     |      |      |
| FA <sub>H</sub>  | <b>CCU6_CC60RL</b> <b>Reset: 00<sub>H</sub></b><br>Capture/Compare Register for Channel CC60 Low          | Bit Field | CC60VL |      |       |      |         |        |      |      |
|                  |   | Type      | rh     |      |       |      |         |        |      |      |
| FB <sub>H</sub>  | <b>CCU6_CC60RH</b> <b>Reset: 00<sub>H</sub></b><br>Capture/Compare Register for Channel CC60 High         | Bit Field | CC60VH |      |       |      |         |        |      |      |
|                  |   | Type      | rh     |      |       |      |         |        |      |      |
| FC <sub>H</sub>  | <b>CCU6_CC61RL</b> <b>Reset: 00<sub>H</sub></b><br>Capture/Compare Register for Channel CC61 Low          | Bit Field | CC61VL |      |       |      |         |        |      |      |
|                  |   | Type      | rh     |      |       |      |         |        |      |      |

**Functional Description**
**Table 12 CCU6 Register Overview (cont'd)**

| Addr             | Register Name   | Bit       | 7        | 6        | 5        | 4        | 3        | 2        | 1        | 0        |  |
|------------------|---|-----------|----------|----------|----------|----------|----------|----------|----------|----------|--|
| FD <sub>H</sub>  | <b>CCU6_CC61RH</b> <b>Reset: 00<sub>H</sub></b><br>Capture/Compare Register for Channel CC61 High     | Bit Field | CC61VH   |          |          |          |          |          |          |          |  |
|                  |   | Type      | rh       |          |          |          |          |          |          |          |  |
| FE <sub>H</sub>  | <b>CCU6_CC62RL</b> <b>Reset: 00<sub>H</sub></b><br>Capture/Compare Register for Channel CC62 Low      | Bit Field | CC62VL   |          |          |          |          |          |          |          |  |
|                  |   | Type      | rh       |          |          |          |          |          |          |          |  |
| FF <sub>H</sub>  | <b>CCU6_CC62RH</b> <b>Reset: 00<sub>H</sub></b><br>Capture/Compare Register for Channel CC62 High     | Bit Field | CC62VH   |          |          |          |          |          |          |          |  |
|                  |   | Type      | rh       |          |          |          |          |          |          |          |  |
| RMAP = 0, Page 2 |   |           |          |          |          |          |          |          |          |          |  |
| 9A <sub>H</sub>  | <b>CCU6_T12MSELL</b> <b>Reset: 00<sub>H</sub></b><br>T12 Capture/Compare Mode Select Register Low     | Bit Field | MSEL61   |          |          |          | MSEL60   |          |          |          |  |
|                  |   | Type      | rw       |          |          |          | rw       |          |          |          |  |
| 9B <sub>H</sub>  | <b>CCU6_T12MSELH</b> <b>Reset: 00<sub>H</sub></b><br>T12 Capture/Compare Mode Select Register High    | Bit Field | DBYP     | HSYNC    |          |          | MSEL62   |          |          |          |  |
|                  |   | Type      | rw       | rw       |          |          | rw       |          |          |          |  |
| 9C <sub>H</sub>  | <b>CCU6_IENL</b> <b>Reset: 00<sub>H</sub></b><br>Capture/Compare Interrupt Enable Register Low        | Bit Field | ENT12 PM | ENT12 OM | ENCC 62F | ENCC 62R | ENCC 61F | ENCC 61R | ENCC 60F | ENCC 60R |  |
|                  |   | Type      | rw       | rw       | rw       | rw       | rw       | rw       | rw       | rw       |  |
| 9D <sub>H</sub>  | <b>CCU6_IENH</b> <b>Reset: 00<sub>H</sub></b><br>Capture/Compare Interrupt Enable Register High       | Bit Field | ENSTR    | EN IDLE  | EN WHE   | EN CHE   | 0        | EN TRPF  | ENT13 PM | ENT13 CM |  |
|                  |   | Type      | rw       | rw       | rw       | rw       | r        | rw       | rw       | rw       |  |
| 9E <sub>H</sub>  | <b>CCU6_INPL</b> <b>Reset: 40<sub>H</sub></b><br>Capture/Compare Interrupt Node Pointer Register Low  | Bit Field | INPCHE   |          | INPCC62  |          | INPCC61  |          | INPCC60  |          |  |
|                  |   | Type      | rw       |          | rw       |          | rw       |          | rw       |          |  |
| 9F <sub>H</sub>  | <b>CCU6_INPH</b> <b>Reset: 39<sub>H</sub></b><br>Capture/Compare Interrupt Node Pointer Register High | Bit Field | 0        |          | INPT13   |          | INPT12   |          | INPERR   |          |  |
|                  |   | Type      | r        |          | rw       |          | rw       |          | rw       |          |  |
| A4 <sub>H</sub>  | <b>CCU6_ISSL</b> <b>Reset: 00<sub>H</sub></b><br>Capture/Compare Interrupt Status Set Register Low    | Bit Field | ST12P M  | ST12O M  | SCC62 F  | SCC62 R  | SCC61 F  | SCC61 R  | SCC60 F  | SCC60 R  |  |
|                  |   | Type      | w        | w        | w        | w        | w        | w        | w        | w        |  |
| A5 <sub>H</sub>  | <b>CCU6_ISSH</b> <b>Reset: 00<sub>H</sub></b><br>Capture/Compare Interrupt Status Set Register High   | Bit Field | SSTR     | SIDLE    | SWHE     | SCHE     | SWHC     | STRPF    | ST13 PM  | ST13 CM  |  |
|                  |   | Type      | w        | w        | w        | w        | w        | w        | w        | w        |  |
| A6 <sub>H</sub>  | <b>CCU6_PSLR</b> <b>Reset: 00<sub>H</sub></b><br>Passive State Level Register                         | Bit Field | PSL63    | 0        |          |          |          |          |          |          |  |
|                  |   | Type      | rwh      | r        | rwh      |          |          |          |          |          |  |
| A7 <sub>H</sub>  | <b>CCU6_MCMCTR</b> <b>Reset: 00<sub>H</sub></b><br>Multi-Channel Mode Control Register                | Bit Field | 0        |          | SWSYN    |          | 0        |          | SWSEL    |          |  |
|                  |   | Type      | r        |          | rw       |          | r        |          | rw       |          |  |
| FA <sub>H</sub>  | <b>CCU6_TCTR2L</b> <b>Reset: 00<sub>H</sub></b><br>Timer Control Register 2 Low                       | Bit Field | 0        | T13TED   |          | T13TEC   |          |          | T13 SSC  | T12 SSC  |  |
|                  |   | Type      | r        | rw       |          | rw       |          |          | rw       | rw       |  |
| FB <sub>H</sub>  | <b>CCU6_TCTR2H</b> <b>Reset: 00<sub>H</sub></b><br>Timer Control Register 2 High                      | Bit Field | 0        |          |          |          | T13RSEL  |          | T12RSEL  |          |  |
|                  |   | Type      | r        |          |          |          | rw       |          | rw       |          |  |
| FC <sub>H</sub>  | <b>CCU6_MODCTRL</b> <b>Reset: 00<sub>H</sub></b><br>Modulation Control Register Low                   | Bit Field | MC MEN   | 0        |          | T12MODEN |          |          |          |          |  |
|                  |   | Type      | rw       | r        |          | rw       |          |          |          |          |  |
| FD <sub>H</sub>  | <b>CCU6_MODCTRH</b> <b>Reset: 00<sub>H</sub></b><br>Modulation Control Register High                  | Bit Field | ECT13 O  | 0        |          | T13MODEN |          |          |          |          |  |
|                  |   | Type      | rw       | r        |          | rw       |          |          |          |          |  |
| FE <sub>H</sub>  | <b>CCU6_TRPCTRL</b> <b>Reset: 00<sub>H</sub></b><br>Trap Control Register Low                         | Bit Field | 0        |          |          |          |          | TRPM2    | TRPM1    | TRPM0    |  |
|                  |   | Type      | r        |          |          |          |          | rw       | rw       | rw       |  |

Functional Description

**Table 12 CCU6 Register Overview (cont'd)**

| Addr             | Register Name  | Bit       | 7       | 6         | 5         | 4       | 3         | 2       | 1         | 0       |
|------------------|--|-----------|---------|-----------|-----------|---------|-----------|---------|-----------|---------|
| FF <sub>H</sub>  | <b>CCU6_TRPCTRH</b> Reset: 00 <sub>H</sub><br>Trap Control Register High                 | Bit Field | TRPPE   | TRPEN     | TRPEN     |         |           |         |           |         |
|                  |  |           | N       | 13        |           |         |           |         |           |         |
|                  |  | Type      | rw      | rw        | rw        |         |           |         |           |         |
| RMAP = 0, Page 3 |  |           |         |           |           |         |           |         |           |         |
| 9A <sub>H</sub>  | <b>CCU6_MCMOUTL</b> Reset: 00 <sub>H</sub><br>Multi-Channel Mode Output Register Low     | Bit Field | 0       | R         | MCOMP     |         |           |         |           |         |
|                  |  | Type      | r       | rh        | rh        |         |           |         |           |         |
| 9B <sub>H</sub>  | <b>CCU6_MCMOUTH</b> Reset: 00 <sub>H</sub><br>Multi-Channel Mode Output Register High    | Bit Field | 0       |           | CURH      |         |           | EXPH    |           |         |
|                  |  | Type      | r       |           | rh        |         |           | rh      |           |         |
| 9C <sub>H</sub>  | <b>CCU6_ISL</b> Reset: 00 <sub>H</sub><br>Capture/Compare Interrupt Status Register Low  | Bit Field | T12PM   | T12OM     | ICC62F    | ICC62R  | ICC61F    | ICC61R  | ICC60F    | ICC60R  |
|                  |  | Type      | rh      | rh        | rh        | rh      | rh        | rh      | rh        | rh      |
| 9D <sub>H</sub>  | <b>CCU6_ISH</b> Reset: 00 <sub>H</sub><br>Capture/Compare Interrupt Status Register High | Bit Field | STR     | IDLE      | WHE       | CHE     | TRPS      | TRPF    | T13PM     | T13CM   |
|                  |  | Type      | rh      | rh        | rh        | rh      | rh        | rh      | rh        | rh      |
| 9E <sub>H</sub>  | <b>CCU6_PISEL0L</b> Reset: 00 <sub>H</sub><br>Port Input Select Register 0 Low           | Bit Field | ISTRP   |           | ISCC62    |         | ISCC61    |         | ISCC60    |         |
|                  |  | Type      | rw      |           | rw        |         | rw        |         | rw        |         |
| 9F <sub>H</sub>  | <b>CCU6_PISEL0H</b> Reset: 00 <sub>H</sub><br>Port Input Select Register 0 High          | Bit Field | IST12HR |           | ISPOS2    |         | ISPOS1    |         | ISPOS0    |         |
|                  |  | Type      | rw      |           | rw        |         | rw        |         | rw        |         |
| A4 <sub>H</sub>  | <b>CCU6_PISEL2</b> Reset: 00 <sub>H</sub><br>Port Input Select Register 2                | Bit Field | 0       |           |           |         |           |         | IST13HR   |         |
|                  |  | Type      | r       |           |           |         |           |         | rw        |         |
| FA <sub>H</sub>  | <b>CCU6_T12L</b> Reset: 00 <sub>H</sub><br>Timer T12 Counter Register Low                | Bit Field | T12CVL  |           |           |         |           |         |           |         |
|                  |  | Type      | rwh     |           |           |         |           |         |           |         |
| FB <sub>H</sub>  | <b>CCU6_T12H</b> Reset: 00 <sub>H</sub><br>Timer T12 Counter Register High               | Bit Field | T12CVH  |           |           |         |           |         |           |         |
|                  |  | Type      | rwh     |           |           |         |           |         |           |         |
| FC <sub>H</sub>  | <b>CCU6_T13L</b> Reset: 00 <sub>H</sub><br>Timer T13 Counter Register Low                | Bit Field | T13CVL  |           |           |         |           |         |           |         |
|                  |  | Type      | rwh     |           |           |         |           |         |           |         |
| FD <sub>H</sub>  | <b>CCU6_T13H</b> Reset: 00 <sub>H</sub><br>Timer T13 Counter Register High               | Bit Field | T13CVH  |           |           |         |           |         |           |         |
|                  |  | Type      | rwh     |           |           |         |           |         |           |         |
| FE <sub>H</sub>  | <b>CCU6_CMPSTATL</b> Reset: 00 <sub>H</sub><br>Compare State Register Low                | Bit Field | 0       | CC63 ST   | CCPO S2   | CCPO S1 | CCPO S0   | CC62 ST | CC61 ST   | CC60 ST |
|                  |  | Type      | r       | rh        | rh        | rh      | rh        | rh      | rh        | rh      |
| FF <sub>H</sub>  | <b>CCU6_CMPSTATH</b> Reset: 00 <sub>H</sub><br>Compare State Register High               | Bit Field | T13IM   | COUT 63PS | COUT 62PS | CC62 PS | COUT 61PS | CC61 PS | COUT 60PS | CC60 PS |
|                  |  | Type      | rwh     | rwh       | rwh       | rwh     | rwh       | rwh     | rwh       | rwh     |

The SSC SFRs can be accessed in the standard memory area (RMAP = 0).

**Table 13 SSC Register Overview**

| Addr            | Register Name   | Bit       | 7  | 6  | 5  | 4  | 3  | 2 | 1   | 0   |     |
|-----------------|---|-----------|----|----|----|----|----|---|-----|-----|-----|
| RMAP = 0        |   |           |    |    |    |    |    |   |     |     |     |
| A9 <sub>H</sub> | <b>SSC_PISEL</b> Reset: 00 <sub>H</sub><br>Port Input Select Register                     | Bit Field | 0  |    |    |    |    |   | CIS | SIS | MIS |
|                 |   | Type      | r  |    |    |    |    |   | rw  | rw  | rw  |
| AA <sub>H</sub> | <b>SSC_CONL</b> Reset: 00 <sub>H</sub><br>Control Register Low<br><i>Programming Mode</i> | Bit Field | LB | PO | PH | HB | BM |   |     |     |     |
|                 |   | Type      | rw | rw | rw | rw | rw |   |     |     |     |
|                 | <i>Operating Mode</i>   | Bit Field | 0  |    |    |    |    |   | BC  |     |     |
|                 |   | Type      | r  |    |    |    |    |   | rh  |     |     |

**Functional Description**
**Table 13 SSC Register Overview**

|                 |   |                              |           |                |    |   |      |     |     |     |     |
|-----------------|---|------------------------------|-----------|----------------|----|---|------|-----|-----|-----|-----|
| AB <sub>H</sub> | <b>SSC_CONH</b><br>Control Register High<br><i>Programming Mode</i> | <b>Reset: 00<sub>H</sub></b> | Bit Field | EN             | MS | 0 | AREN | BEN | PEN | REN | TEN |
|                 |   |                              | Type      | rw             | rw | r | rw   | rw  | rw  | rw  | rw  |
|                 | <i>Operating Mode</i>   |                              | Bit Field | EN             | MS | 0 | BSY  | BE  | PE  | RE  | TE  |
|                 |   |                              | Type      | rw             | rw | r | rh   | rwh | rwh | rwh | rwh |
| AC <sub>H</sub> | <b>SSC_TBL</b><br>Transmitter Buffer Register Low                   | <b>Reset: 00<sub>H</sub></b> | Bit Field | TB_VALUE       |    |   |      |     |     |     |     |
|                 |   |                              | Type      | rw             |    |   |      |     |     |     |     |
| AD <sub>H</sub> | <b>SSC_RBL</b><br>Receiver Buffer Register Low                      | <b>Reset: 00<sub>H</sub></b> | Bit Field | RB_VALUE       |    |   |      |     |     |     |     |
|                 |   |                              | Type      | rh             |    |   |      |     |     |     |     |
| AE <sub>H</sub> | <b>SSC_BRL</b><br>Baudrate Timer Reload Register Low                | <b>Reset: 00<sub>H</sub></b> | Bit Field | BR_VALUE[7:0]  |    |   |      |     |     |     |     |
|                 |   |                              | Type      | rw             |    |   |      |     |     |     |     |
| AF <sub>H</sub> | <b>SSC_BRH</b><br>Baudrate Timer Reload Register High               | <b>Reset: 00<sub>H</sub></b> | Bit Field | BR_VALUE[15:8] |    |   |      |     |     |     |     |
|                 |   |                              | Type      | rw             |    |   |      |     |     |     |     |

The OCDS SFRs can be accessed in the mapped memory area (RMAP = 1).

**Table 14 OCDS Register Overview**

| Addr            | Register Name   | Bit                          | 7         | 6       | 5     | 4        | 3      | 2        | 1      | 0      |        |
|-----------------|---|------------------------------|-----------|---------|-------|----------|--------|----------|--------|--------|--------|
| RMAP = 1        |   |                              |           |         |       |          |        |          |        |        |        |
| E9 <sub>H</sub> | <b>MMCR2</b><br>Monitor Mode Control Register 2             | <b>Reset: 00<sub>H</sub></b> | Bit Field | EXBC_P  | EXBC  | MBCO_N_P | MBCO_N | MMEP_P   | MMEP   | MMOD_E | JENA   |
|                 |   |                              | Type      | w       | rw    | w        | rwh    | w        | rwh    | rh     | rh     |
| F1 <sub>H</sub> | <b>MMCR</b><br>Monitor Mode Control Register                | <b>Reset: 00<sub>H</sub></b> | Bit Field | MEXIT_P | MEXIT | MSTEP_P  | MSTEP  | MRAM_S_P | MRAM_S | TRF    | RRF    |
|                 |   |                              | Type      | w       | rwh   | w        | rw     | w        | rwh    | rh     | rh     |
| F2 <sub>H</sub> | <b>MMSR</b><br>Monitor Mode Status Register                 | <b>Reset: 00<sub>H</sub></b> | Bit Field | MBCA_M  | MBCIN | EXBF     | SWBF   | HWB3_F   | HWB2_F | HWB1_F | HWB0_F |
|                 |   |                              | Type      | rw      | rh    | rwh      | rwh    | rwh      | rwh    | rwh    | rwh    |
| F3 <sub>H</sub> | <b>MMBPCR</b><br>BreakPoints Control Register               | <b>Reset: 00<sub>H</sub></b> | Bit Field | SWBC    | HWB3C |          | HWB2C  |          | HWB1_C | HWB0C  |        |
|                 |   |                              | Type      | rw      | rw    |          | rw     |          | rw     | rw     |        |
| F4 <sub>H</sub> | <b>MMICR</b><br>Monitor Mode Interrupt Control Register     | <b>Reset: 00<sub>H</sub></b> | Bit Field | DVECT   | DRETR | 0        |        | MMUIE_P  | MMUIE  | RRIE_P | RRIE   |
|                 |   |                              | Type      | rwh     | rwh   | r        |        | w        | rw     | w      | rw     |
| F5 <sub>H</sub> | <b>MMDR</b><br>Monitor Mode Data Register<br><i>Receive</i> |                              | Bit Field | MMRR    |       |          |        |          |        |        |        |
|                 |   |                              | Type      | rh      |       |          |        |          |        |        |        |
|                 | <i>Transmit</i>   |                              | Bit Field | MMTR    |       |          |        |          |        |        |        |
|                 |   |                              | Type      | w       |       |          |        |          |        |        |        |
| F6 <sub>H</sub> | <b>HWBPSR</b><br>Hardware Breakpoints Select Register       | <b>Reset: 00<sub>H</sub></b> | Bit Field | 0       |       | BPSEL_P  | BPSEL  |          |        |        |        |
|                 |   |                              | Type      | r       |       | w        | rw     |          |        |        |        |
| F7 <sub>H</sub> | <b>HWBPDR</b><br>Hardware Breakpoints Data Register         | <b>Reset: 00<sub>H</sub></b> | Bit Field | HWBPxx  |       |          |        |          |        |        |        |
|                 |   |                              | Type      | rw      |       |          |        |          |        |        |        |



### 3.3 Flash Memory

The Flash memory provides an embedded user-programmable non-volatile memory, allowing fast and reliable storage of user code and data. It is operated from a single 2.5 V supply from the Embedded Voltage Regulator (EVR) and does not require additional programming or erasing voltage. The sectorization of the Flash memory allows each sector to be erased independently.

#### Features

- In-System Programming (ISP) via UART
- In-Application Programming (IAP)
- Error Correction Code (ECC) for dynamic correction of single-bit errors
- Background program and erase operations for CPU load minimization
- Support for aborting erase operation
- Minimum program width<sup>1)</sup> of 32-byte for D-Flash and 32-byte for P-Flash
- 1-sector minimum erase width
- 1-byte read access
- Flash is delivered in erased state (read all zeros)
- Operating supply voltage: 2.5 V  $\pm$  7.5 %
- Read access time:  $3 \times t_{\text{CCLK}} = 112.5 \text{ ns}^2)$
- Program time:  $209440 / f_{\text{SYS}} = 2.6 \text{ ms}^3)$
- Erase time:  $8175360 / f_{\text{SYS}} = 102 \text{ ms}^3)$

<sup>1)</sup> P-Flash: 32-byte wordline can only be programmed once, i.e., one gate disturb allowed.  
D-Flash: 32-byte wordline can be programmed twice, i.e., two gate disturbs allowed.

<sup>2)</sup>  $f_{\text{SYS}} = 80 \text{ MHz} \pm 7.5\%$  ( $f_{\text{CCLK}} = 26.7 \text{ MHz} \pm 7.5\%$ ) is the maximum frequency range for Flash read access.

<sup>3)</sup>  $f_{\text{SYS}} = 80 \text{ MHz} \pm 7.5\%$  is the only frequency range for Flash programming and erasing.  $f_{\text{SYSmin}}$  is used for obtaining the worst case timing.

**Functional Description**

**Table 15** shows the Flash data retention and endurance targets.

**Table 15 Flash Data Retention and Endurance**

| Retention            | Endurance <sup>1)</sup>      | Size                          |                         | Remarks              |
|----------------------|------------------------------|-------------------------------|-------------------------|----------------------|
|                      |                              | $T_A = -40$ to $125$ °C       | $T_A = 125$ to $140$ °C |                      |
| <b>Program Flash</b> |                              |                               |                         |                      |
| 20 years             | 1,000 cycles                 | up to 16 Kbytes <sup>2)</sup> |                         | for 16-Kbyte Variant |
| 20 years             | 1,000 cycles                 | up to 8 Kbytes <sup>2)</sup>  |                         | for 8-Kbyte Variant  |
| 20 years             | 1,000 cycles                 | up to 4 Kbytes <sup>2)</sup>  |                         | for 4-Kbyte Variant  |
| <b>Data Flash</b>    |                              |                               |                         |                      |
| 20 years             | 1,000 cycles <sup>3)</sup>   | 4 Kbytes                      | 1 Kbytes                |                      |
| 5 years              | 10,000 cycles <sup>3)</sup>  | 1 Kbyte                       | 256 bytes               |                      |
| 2 years              | 70,000 cycles <sup>3)</sup>  | 512 bytes                     | 128 bytes               |                      |
| 2 years              | 100,000 cycles <sup>3)</sup> | 128 bytes                     | 32 bytes                |                      |

<sup>1)</sup> One cycle refers to the programming of all wordlines in a sector and erasing of sector. The Flash endurance data specified in **Table 15** is valid only if the following conditions are fulfilled:

- the maximum number of erase cycles per Flash sector must not exceed 100,000 cycles.
- the maximum number of erase cycles per Flash bank must not exceed 300,000 cycles.
- the maximum number of program cycles per Flash bank must not exceed 2,500,000 cycles.

<sup>2)</sup> If no Flash is used for data, the Program Flash size can be up to the maximum Flash size available in the device variant. Having more Data Flash will mean less Flash is available for Program Flash.

<sup>3)</sup> For  $T_A = 125$  to  $140$  °C, refers to programming of second 8 bytes (bytes 8 to 15) per WL

### 3.3.1 Flash Bank Sectorization

The SAA-XC866 product family offers four Flash devices with either 8 Kbytes or 16 Kbytes of embedded Flash memory. These Flash memory sizes are made up of two or four 4-Kbyte Flash banks, respectively. Each Flash device consists of Program Flash (P-Flash) bank(s) and a single Data Flash (D-Flash) bank with different sectorization shown in **Figure 11**. Both types can be used for code and data storage. The label “Data” neither implies that the D-Flash is mapped to the data memory region, nor that it can only be used for data storage. It is used to distinguish the different Flash bank sectorizations.

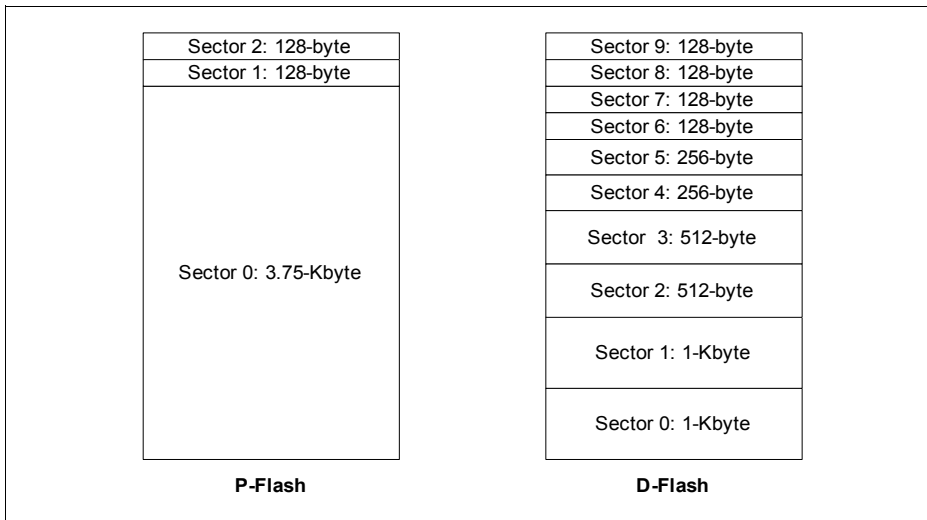

**Figure 11 Flash Bank Sectorization**

The internal structure of each Flash bank represents a sector architecture for flexible erase capability. The minimum erase width is always a complete sector, and sectors can be erased separately or in parallel. Contrary to standard EPROMs, erased Flash memory cells contain 0s.

The D-Flash bank is divided into more physical sectors for extended erasing and reprogramming capability; even numbers for each sector size are provided to allow greater flexibility and the ability to adapt to a wide range of application requirements.

### 3.3.2 Flash Programming Width

For the P-Flash banks, a programmed wordline (WL) must be erased before it can be reprogrammed as the Flash cells can only withstand one gate disturb. This means that the entire sector containing the WL must be erased since it is impossible to erase a single WL.

For the D-Flash bank, the same WL can be programmed twice before erasing is required as the Flash cells are able to withstand two gate disturbs. Hence, it is possible to program the same WL, for example, with 16 bytes of data in two times (see [Figure 12](#)).

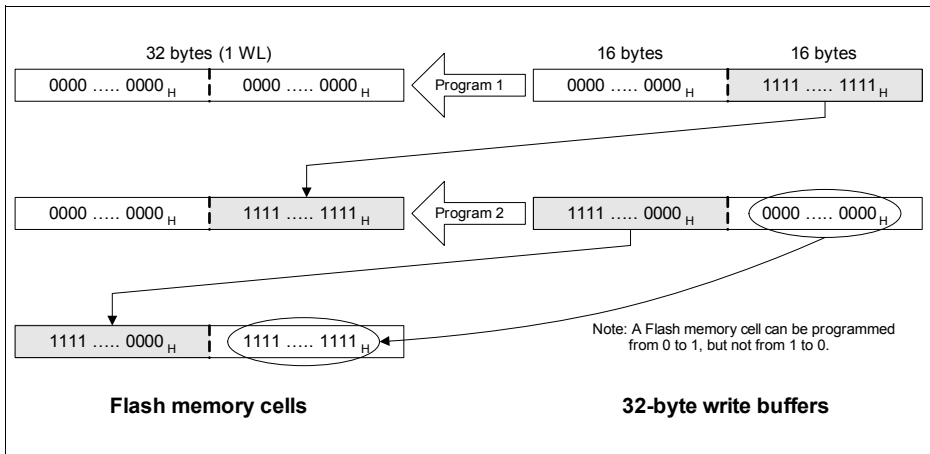

Figure 12 D-Flash Programming

*Note: When programming a D-Flash WL the second time, the previously programmed Flash memory cells (whether 0s or 1s) should be reprogrammed with 0s to retain its original contents and to prevent “over-programming”.*

### 3.4 Interrupt System

The XC800 Core supports one non-maskable interrupt (NMI) and 14 maskable interrupt requests. In addition to the standard interrupt functions supported by the core, e.g., configurable interrupt priority and interrupt masking, the XC866 interrupt system provides extended interrupt support capabilities such as the mapping of each interrupt vector to several interrupt sources to increase the number of interrupt sources supported, and additional status registers for detecting and determining the interrupt source.

#### 3.4.1 Interrupt Source

Figure 13 to Figure 17 give a general overview of the interrupt sources and illustrates the request and control flags.

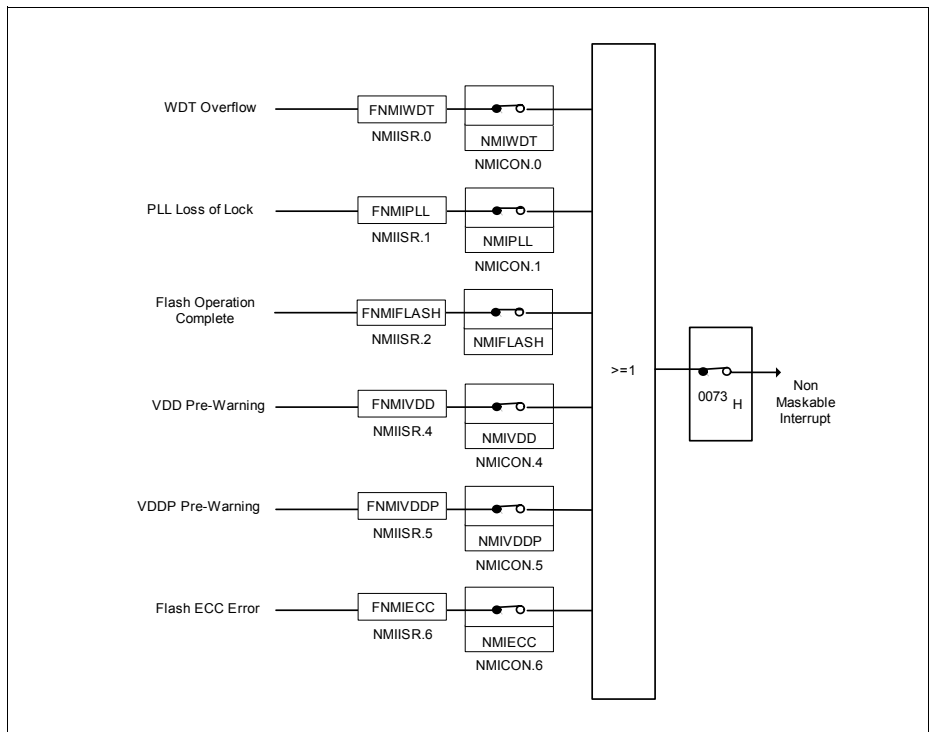

Figure 13 Non-Maskable Interrupt Request Sources

Functional Description

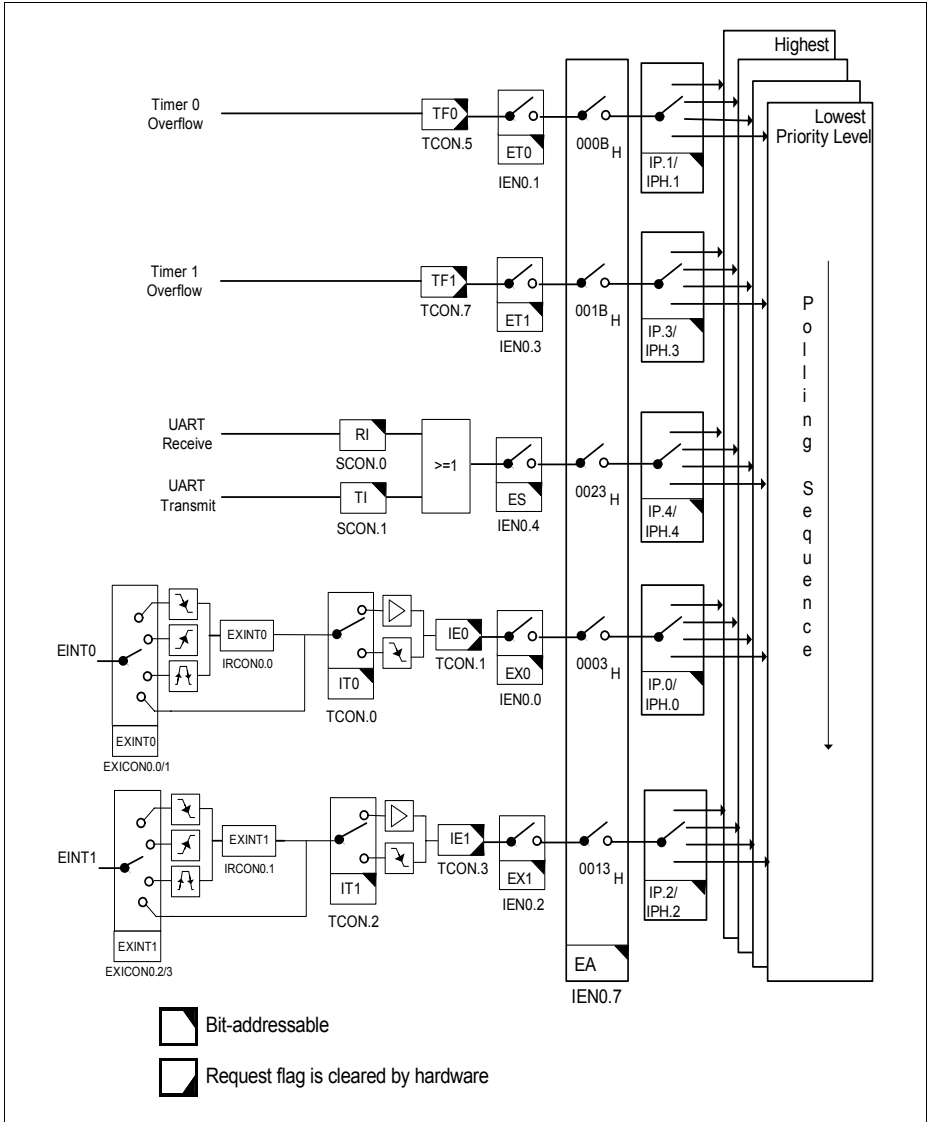

Figure 14 Interrupt Request Sources (Part 1)

Functional Description

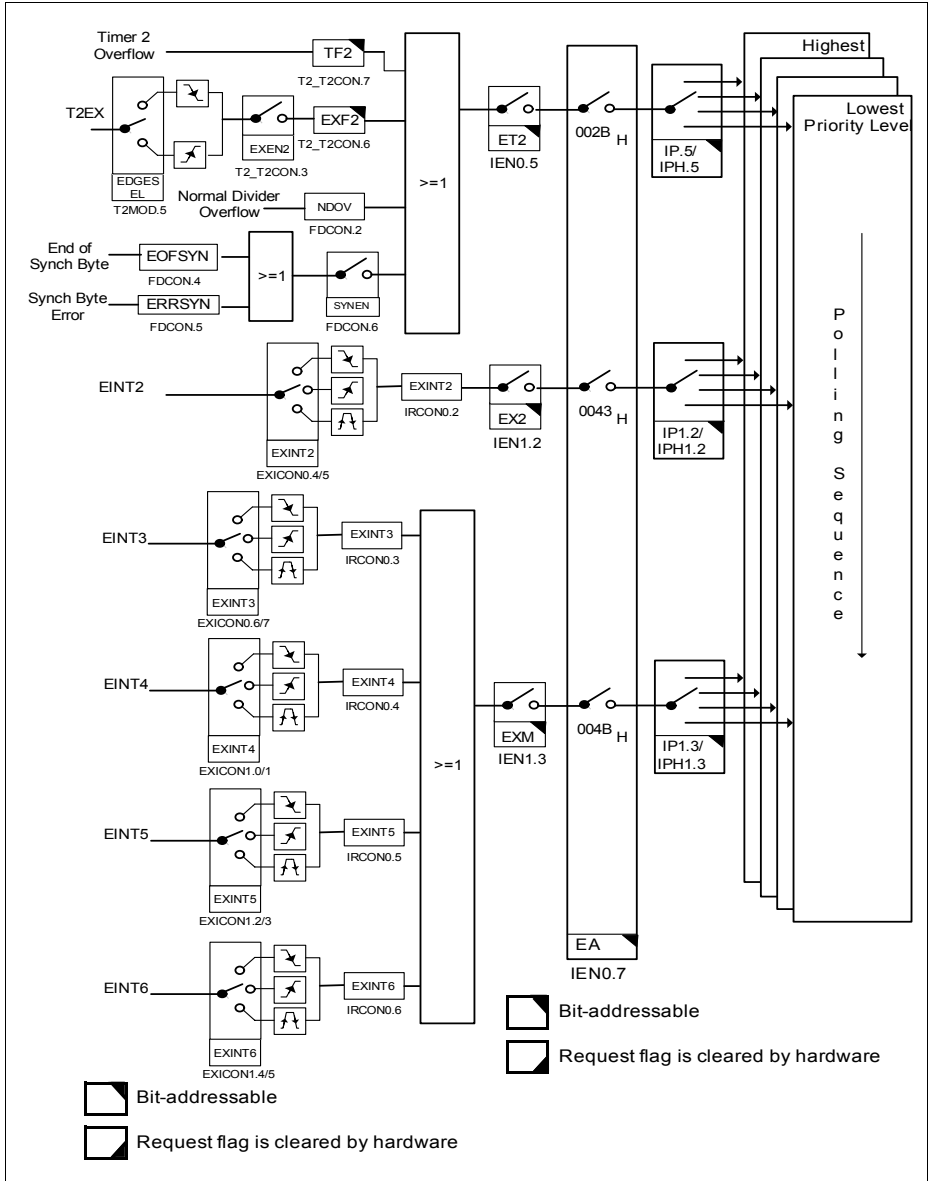

Figure 15 Interrupt Request Sources (Part 2)

Functional Description

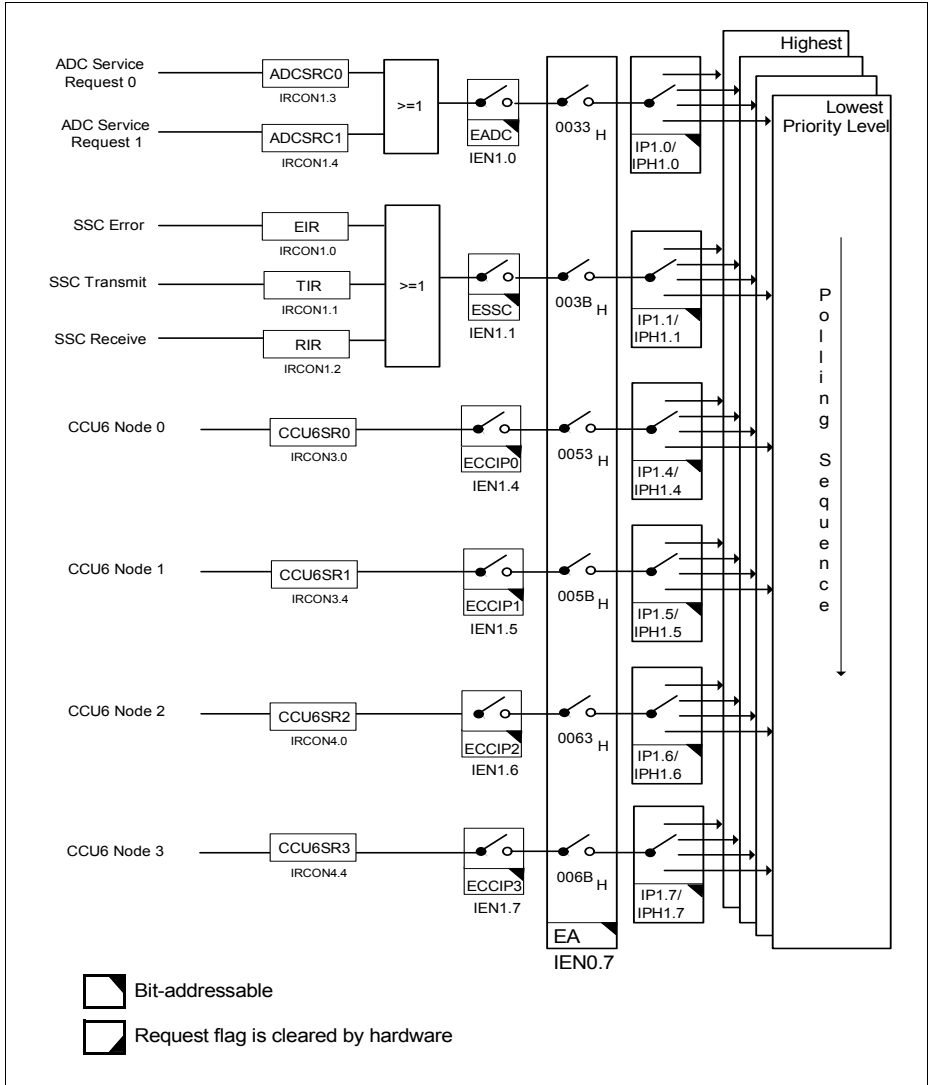

Figure 16 Interrupt Request Sources (Part 3)



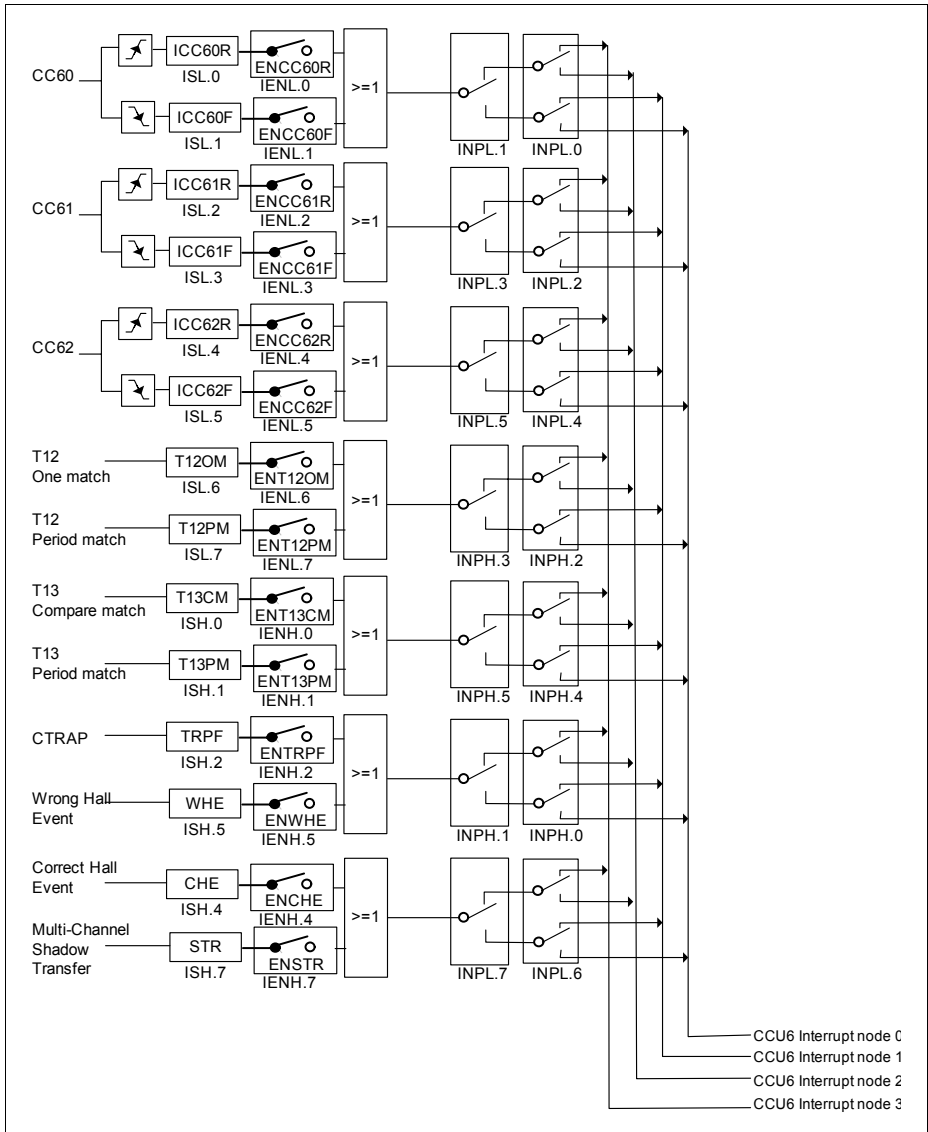

Figure 17 Interrupt Request Sources (Part 4)

### 3.4.2 Interrupt Source and Vector

Each interrupt source has an associated interrupt vector address. This vector is accessed to service the corresponding interrupt source request. The interrupt service of each interrupt source can be individually enabled or disabled via an enable bit. The assignment of the SAA-XC866 interrupt sources to the interrupt vector addresses and the corresponding interrupt source enable bits are summarized in [Table 16](#).

**Table 16 Interrupt Vector Addresses**

| Interrupt Source | Vector Address    | Assignment for SAA-XC866                     | Enable Bit | SFR    |
|------------------|-------------------|--|------------|--------|
| NMI              | 0073 <sub>H</sub> | Watchdog Timer NMI                           | NMIWDT     | NMICON |
|                  |                   | PLL NMI                                      | NMIPLL     |        |
|                  |                   | Flash NMI                                    | NMIFLASH   |        |
|                  |                   | VDDC Prewarning NMI                          | NMIVDD     |        |
|                  |                   | VDDP Prewarning NMI                          | NMIVDDP    |        |
|                  |                   | Flash ECC NMI                                | NMIECC     |        |
| XINTR0           | 0003 <sub>H</sub> | External Interrupt 0                         | EX0        | IEN0   |
| XINTR1           | 000B <sub>H</sub> | Timer 0                                      | ET0        |        |
| XINTR2           | 0013 <sub>H</sub> | External Interrupt 1                         | EX1        |        |
| XINTR3           | 001B <sub>H</sub> | Timer 1                                      | ET1        |        |
| XINTR4           | 0023 <sub>H</sub> | UART   | ES         |        |
| XINTR5           | 002B <sub>H</sub> | T2   | ET2        |        |
|                  |                   | Fractional Divider (Normal Divider Overflow) |            |        |
|                  |                   | LIN  |            |        |

**Table 16**    **Interrupt Vector Addresses (cont'd)**

|         |                   |                      |        |      |
|---------|-------------------|----------------------|--------|------|
| XINTR6  | 0033 <sub>H</sub> | ADC                  | EADC   | IEN1 |
| XINTR7  | 003B <sub>H</sub> | SSC                  | ESSC   |      |
| XINTR8  | 0043 <sub>H</sub> | External Interrupt 2 | EX2    |      |
| XINTR9  | 004B <sub>H</sub> | External Interrupt 3 | EXM    |      |
|         |                   | External Interrupt 4 |        |      |
|         |                   | External Interrupt 5 |        |      |
|         |                   | External Interrupt 6 |        |      |
| XINTR10 | 0053 <sub>H</sub> | CCU6 INP0            | ECCIP0 |      |
| XINTR11 | 005B <sub>H</sub> | CCU6 INP1            | ECCIP1 |      |
| XINTR12 | 0063 <sub>H</sub> | CCU6 INP2            | ECCIP2 |      |
| XINTR13 | 006B <sub>H</sub> | CCU6 INP3            | ECCIP3 |      |

### 3.4.3 Interrupt Priority

Each interrupt source, except for NMI, can be individually programmed to one of the four possible priority levels. The NMI has the highest priority and supersedes all other interrupts. Two pairs of interrupt priority registers (IP and IPH, IP1 and IPH1) are available to program the priority level of each non-NMI interrupt vector.

A low-priority interrupt can be interrupted by a high-priority interrupt, but not by another interrupt of the same or lower priority. Further, an interrupt of the highest priority cannot be interrupted by any other interrupt source.

If two or more requests of different priority levels are received simultaneously, the request of the highest priority is serviced first. If requests of the same priority are received simultaneously, then an internal polling sequence determines which request is serviced first. Thus, within each priority level, there is a second priority structure determined by the polling sequence shown in [Table 17](#).

**Table 17 Priority Structure within Interrupt Level**

| Source                                      | Level     |
|---|-----------|
| Non-Maskable Interrupt (NMI)                | (highest) |
| External Interrupt 0                        | 1         |
| Timer 0 Interrupt                           | 2         |
| External Interrupt 1                        | 3         |
| Timer 1 Interrupt                           | 4         |
| UART Interrupt                              | 5         |
| Timer 2, Fractional Divider, LIN Interrupts | 6         |
| ADC Interrupt                               | 7         |
| SSC Interrupt                               | 8         |
| External Interrupt 2                        | 9         |
| External Interrupt [6:3]                    | 10        |
| CCU6 Interrupt Node Pointer 0               | 11        |
| CCU6 Interrupt Node Pointer 1               | 12        |
| CCU6 Interrupt Node Pointer 2               | 13        |
| CCU6 Interrupt Node Pointer 3               | 14        |

### 3.5 Parallel Ports

The SAA-XC866 has 27 port pins organized into four parallel ports, Port 0 (P0) to Port 3 (P3). Each pin has a pair of internal pull-up and pull-down devices that can be individually enabled or disabled. Ports P0, P1 and P3 are bidirectional and can be used as general purpose input/output (GPIO) or to perform alternate input/output functions for the on-chip peripherals. When configured as an output, the open drain mode can be selected. Port P2 is an input-only port, providing general purpose input functions, alternate input functions for the on-chip peripherals, and also analog inputs for the Analog-to-Digital Converter (ADC).

#### **Bidirectional Port Features:**

- Configurable pin direction
- Configurable pull-up/pull-down devices
- Configurable open drain mode
- Transfer of data through digital inputs and outputs (general purpose I/O)
- Alternate input/output for on-chip peripherals

#### **Input Port Features:**

- Configurable input driver
- Configurable pull-up/pull-down devices
- Receive of data through digital input (general purpose input)
- Alternate input for on-chip peripherals
- Analog input for ADC module

Functional Description

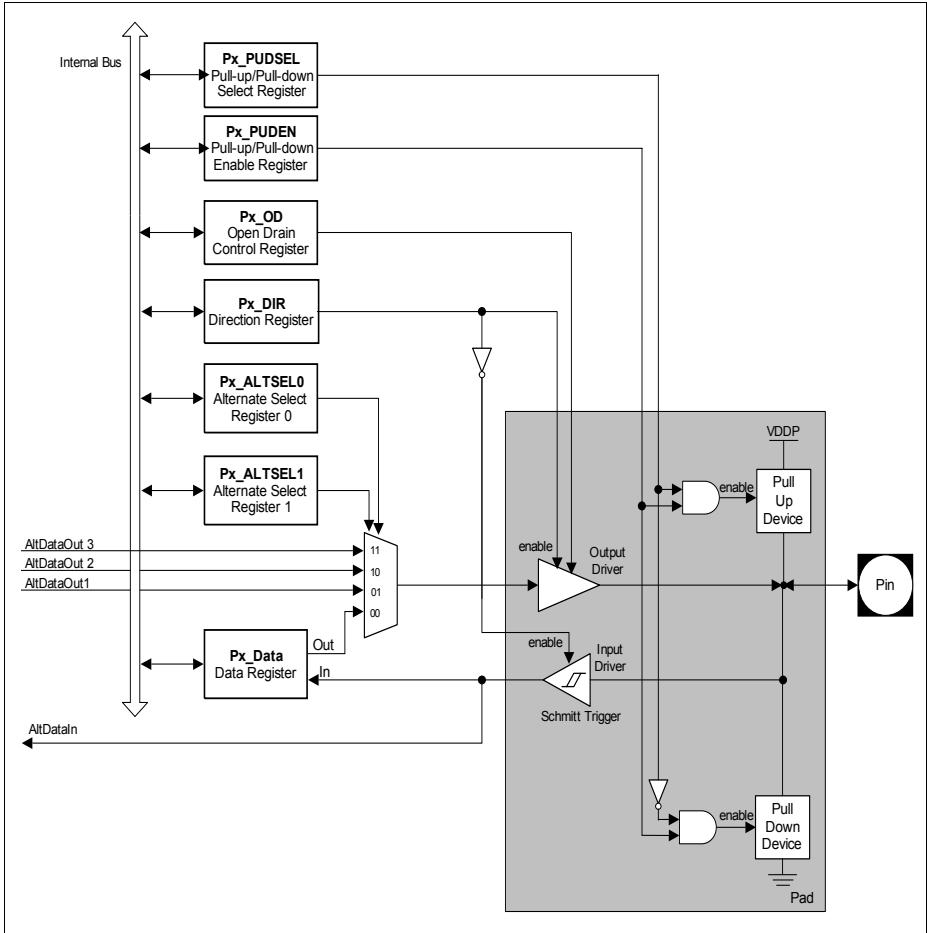

Figure 18 General Structure of Bidirectional Port

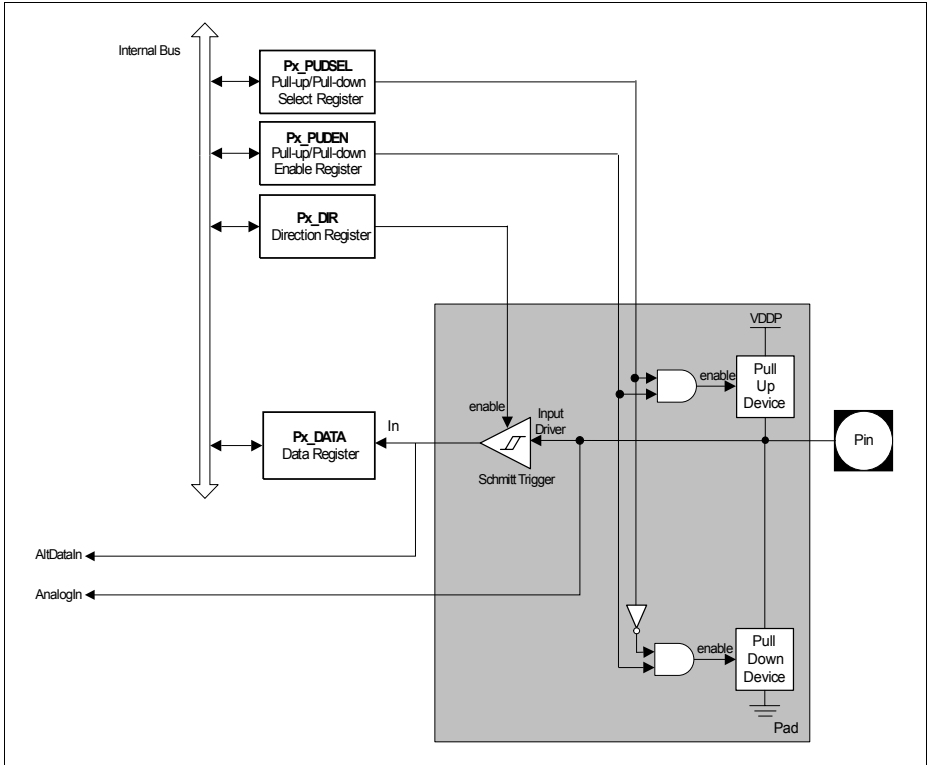

Figure 19 General Structure of Input Port

### 3.6 Power Supply System with Embedded Voltage Regulator

The SAA-XC866 microcontroller requires two different levels of power supply:

- 5.0 V for the Embedded Voltage Regulator (EVR) and Ports
- 2.5 V for the core, memory, on-chip oscillator, and peripherals

**Figure 20** shows the SAA-XC866 power supply system. A power supply of 5.0 V must be provided from the external power supply pin. The 2.5 V power supply for the logic is generated by the EVR. The EVR helps to reduce the power consumption of the whole chip and the complexity of the application board design.

The EVR consists of a main voltage regulator and a low power voltage regulator. In active mode, both voltage regulators are enabled. In power-down mode, the main voltage regulator is switched off, while the low power voltage regulator continues to function and provide power supply to the system with low power consumption.

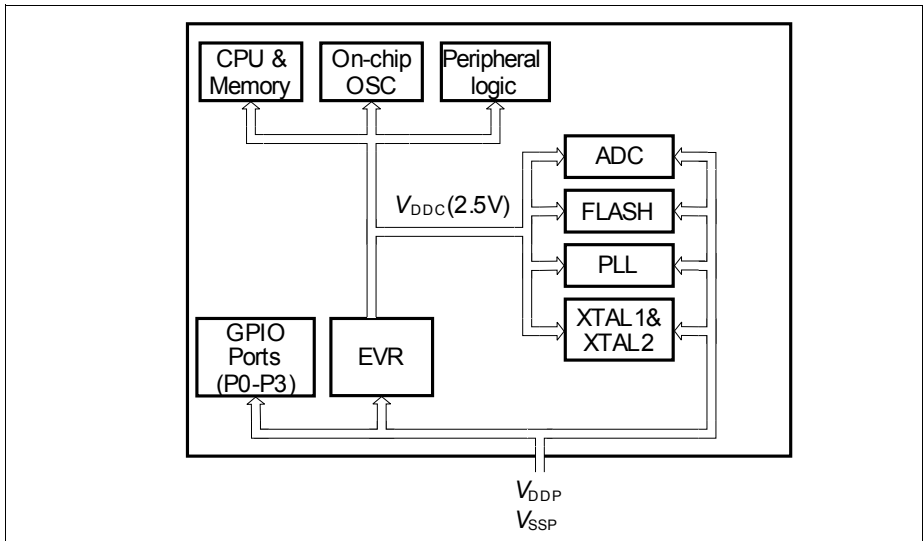

**Figure 20 SAA-XC866 Power Supply System**

#### EVR Features:

- Input voltage ( $V_{DDP}$ ): 5.0 V
- Output voltage ( $V_{DDC}$ ): 2.5 V  $\pm$  7.5%
- Low power voltage regulator provided in power-down mode
- $V_{DDC}$  and  $V_{DDP}$  prewarning detection
- $V_{DDC}$  brownout detection



### 3.7 Reset Control

The SAA-XC866 has five types of reset: power-on reset, hardware reset, watchdog timer reset, power-down wake-up reset, and brownout reset.

When the SAA-XC866 is first powered up, the status of certain pins (see [Table 19](#)) must be defined to ensure proper start operation of the device. At the end of a reset sequence, the sampled values are latched to select the desired boot option, which cannot be modified until the next power-on reset or hardware reset. This guarantees stable conditions during the normal operation of the device.

In order to power up the system properly, the external reset pin  $\overline{\text{RESET}}$  must be asserted until  $V_{\text{DDC}}$  reaches  $0.9 \cdot V_{\text{DDC}}$ . The delay of external reset can be realized by an external capacitor at  $\overline{\text{RESET}}$  pin. This capacitor value must be selected so that  $V_{\text{RESET}}$  reaches 0.4 V, but not before  $V_{\text{DDC}}$  reaches  $0.9 \cdot V_{\text{DDC}}$ .

A typical application example is shown in [Figure 21](#).  $V_{\text{DDP}}$  capacitor value is 300 nF.  $V_{\text{DDC}}$  capacitor value is 220 nF. The capacitor connected to  $\overline{\text{RESET}}$  pin is 100 nF.

Typically, the time taken for  $V_{\text{DDC}}$  to reach  $0.9 \cdot V_{\text{DDC}}$  is less than 50  $\mu\text{s}$  once  $V_{\text{DDP}}$  reaches 2.3V. Hence, based on the condition that 10% to 90%  $V_{\text{DDP}}$  (slew rate) is less than 500  $\mu\text{s}$ , the  $\overline{\text{RESET}}$  pin should be held low for 500  $\mu\text{s}$  typically. See [Figure 22](#).

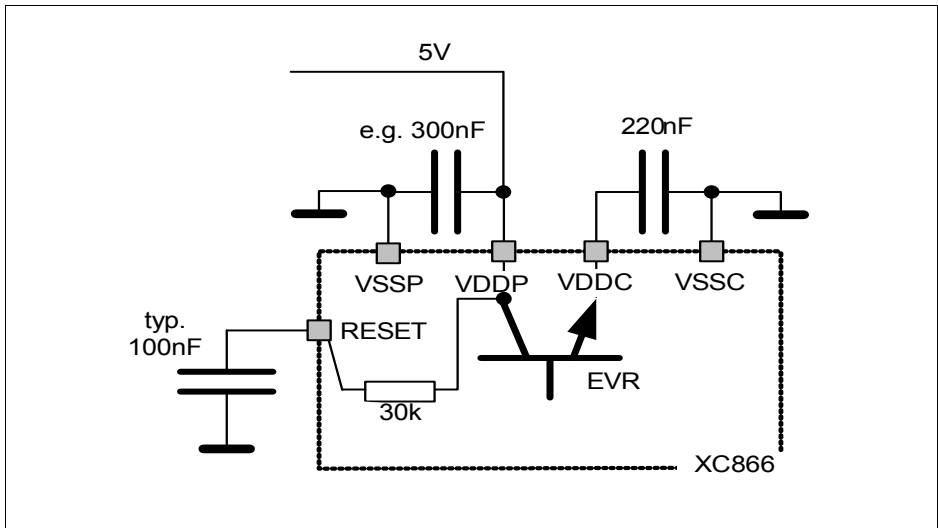
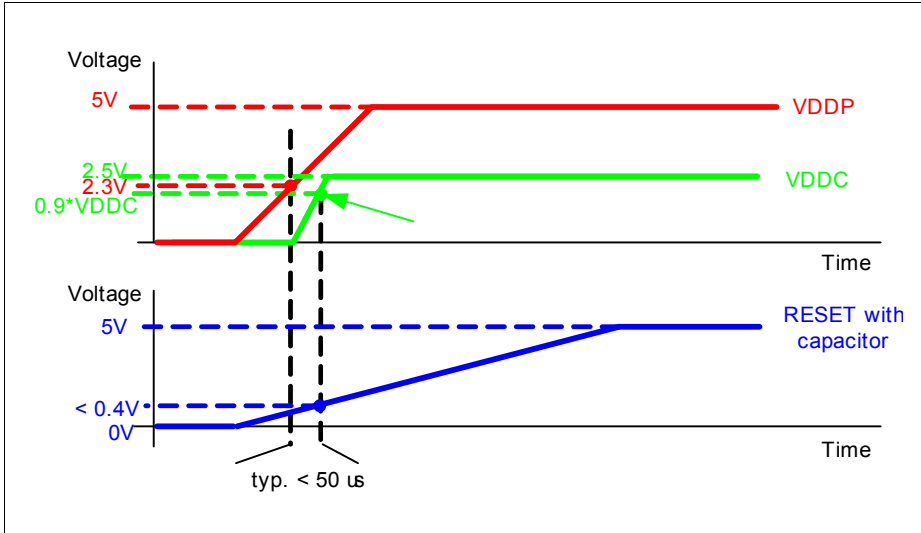

Figure 21 Reset Circuitry



**Figure 22**  $V_{DDP}$ ,  $V_{DDC}$  and  $V_{RESET}$  during Power-on Reset

The second type of reset in SAA-XC866 is the hardware reset. This reset function can be used during normal operation or when the chip is in power-down mode. A reset input pin RESET is provided for the hardware reset. To ensure the recognition of the hardware reset, pin RESET must be held low for at least 100 ns.

The Watchdog Timer (WDT) module is also capable of resetting the device if it detects a malfunction in the system.

Another type of reset that needs to be detected is a reset while the device is in power-down mode (wake-up reset). While the contents of the static RAM are undefined after a power-on reset, they are well defined after a wake-up reset from power-down mode.

### 3.7.1 Module Reset Behavior

**Table 18** shows how the functions of the SAA-XC866 are affected by the various reset types. A “■” means that this function is reset to its default state.

**Table 18 Effect of Reset on Device Functions**

| Module/<br>Function           | Wake-Up<br>Reset                           | Watchdog<br>Reset         | Hardware<br>Reset         | Power-On<br>Reset         | Brownout<br>Reset         |
|-------------------------------|--|---------------------------|---------------------------|---------------------------|---------------------------|
| <b>CPU Core</b>               | ■  | ■                         | ■                         | ■                         | ■                         |
| <b>Peripherals</b>            | ■  | ■                         | ■                         | ■                         | ■                         |
| <b>On-Chip<br/>Static RAM</b> | Not affected,<br>reliable                  | Not affected,<br>reliable | Not affected,<br>reliable | Affected, un-<br>reliable | Affected, un-<br>reliable |
| <b>Oscillator,<br/>PLL</b>    | ■  | Not affected              | ■                         | ■                         | ■                         |
| <b>Port Pins</b>              | ■  | ■                         | ■                         | ■                         | ■                         |
| <b>EVR</b>                    | The voltage<br>regulator is<br>switched on | Not affected              | ■                         | ■                         | ■                         |
| <b>FLASH</b>                  | ■  | ■                         | ■                         | ■                         | ■                         |
| <b>NMI</b>                    | Disabled                                   | Disabled                  | ■                         | ■                         | ■                         |

### 3.7.2 Booting Scheme

When the SAA-XC866 is reset, it must identify the type of configuration with which to start the different modes once the reset sequence is complete. Thus, boot configuration information that is required for activation of special modes and conditions needs to be applied by the external world through input pins. After power-on reset or hardware reset, the pins MBC, TMS and P0.0 collectively select the different boot options. **Table 19** shows the available boot options in the SAA-XC866.

**Table 19 SAA-XC866 Boot Selection**

| MBC | TMS | P0.0 | Type of Mode  | PC Start Value    |
|-----|-----|------|---|-------------------|
| 1   | 0   | x    | User Mode; on-chip OSC/PLL non-bypassed   | 0000 <sub>H</sub> |
| 0   | 0   | x    | BSL Mode; on-chip OSC/PLL non-bypassed  | 0000 <sub>H</sub> |
| 0   | 1   | 0    | OCDS Mode <sup>1)</sup> ; on-chip OSC/PLL non-bypassed                            | 0000 <sub>H</sub> |
| 1   | 1   | 0    | Standalone User (JTAG) Mode <sup>2)</sup> ; on-chip OSC/PLL non-bypassed (normal) | 0000 <sub>H</sub> |

<sup>1)</sup> The OCDS mode is not accessible if Flash is protected.

<sup>2)</sup> Normal user mode with standard JTAG (TCK,TDI,TDO) pins for hot-attach purpose.

### 3.8 Clock Generation Unit

The Clock Generation Unit (CGU) allows great flexibility in the clock generation for the SAA-XC866. The power consumption is indirectly proportional to the frequency, whereas the performance of the microcontroller is directly proportional to the frequency. During user program execution, the frequency can be programmed for an optimal ratio between performance and power consumption. Therefore the power consumption can be adapted to the actual application state.

**Features:**

- Phase-Locked Loop (PLL) for multiplying clock source by different factors
- PLL Base Mode
- Prescaler Mode
- PLL Mode
- Power-down mode support

The CGU consists of an oscillator circuit and a PLL. In the SAA-XC866, the oscillator can be from either of these two sources: the on-chip oscillator (10 MHz) or the external oscillator (4 MHz to 12 MHz). The term “oscillator” is used to refer to both on-chip oscillator and external oscillator, unless otherwise stated. After the reset, the on-chip oscillator will be used by default. The external oscillator can be selected via software. In addition, the PLL provides a fail-safe logic to perform oscillator run and loss-of-lock detection. This allows emergency routines to be executed for system recovery or to perform system shut down.

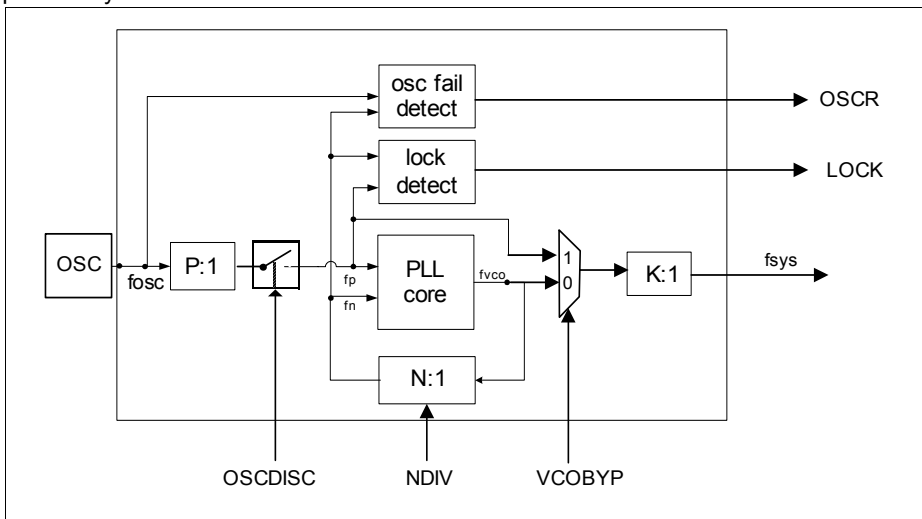

**Figure 23 CGU Block Diagram**

The clock system provides three ways to generate the system clock:

### PLL Base Mode

The system clock is derived from the VCO base (free running) frequency clock divided by the K factor.

$$f_{SYS} = f_{VCObase} \times \frac{1}{K}$$

### Prescaler Mode (VCO Bypass Operation)

In VCO bypass operation, the system clock is derived from the oscillator clock, divided by the P and K factors.

$$f_{SYS} = f_{OSC} \times \frac{1}{P \times K}$$

### PLL Mode

The system clock is derived from the oscillator clock, multiplied by the N factor, and divided by the P and K factors. Both VCO bypass and PLL bypass must be inactive for this PLL mode. The PLL mode is used during normal system operation. .

$$f_{SYS} = f_{OSC} \times \frac{N}{P \times K}$$

**Table 20** shows the settings of bits OSCDISC and VCOBYP for different clock mode selection.

**Table 20 Clock Mode Selection**

| OSCDISC | VCOBYP | Clock Working Modes |
|---------|--------|---------------------|
| 0       | 0      | PLL Mode            |
| 0       | 1      | Prescaler Mode      |
| 1       | 0      | PLL Base Mode       |
| 1       | 1      | PLL Base Mode       |

*Note: When oscillator clock is disconnected from PLL, the clock mode is PLL Base mode regardless of the setting of VCOBYP bit.*

### System Frequency Selection

For the SAA-XC866, the values of P and K are fixed to “1” and “2”, respectively. In order to obtain the required system frequency,  $f_{SYS}$ , the value of N can be selected by bit NDIV for different oscillator inputs. **Table 21** provides examples on how  $f_{SYS} = 80$  MHz can be obtained for the different oscillator sources.

**Table 21 System frequency ( $f_{\text{sys}} = 80 \text{ MHz}$ )**

| Oscillator | fosc   | N  | P | K | fsys   |
|------------|--------|----|---|---|--------|
| On-chip    | 10 MHz | 16 | 1 | 2 | 80 MHz |
| External   | 10 MHz | 16 | 1 | 2 | 80 MHz |
|            | 8 MHz  | 20 | 1 | 2 | 80 MHz |
|            | 5 MHz  | 32 | 1 | 2 | 80 MHz |

**Table 22** shows the VCO range for the SAA-XC866.

**Table 22 VCO Range**

| $f_{\text{VCOmin}}$ | $f_{\text{VCOmax}}$ | $f_{\text{VCOFREEmin}}$ | $f_{\text{VCOFREEmax}}$ | Unit |
|---------------------|---------------------|-------------------------|-------------------------|------|
| 150                 | 200                 | 20                      | 80                      | MHz  |
| 100                 | 150                 | 10                      | 80                      | MHz  |

### 3.8.1 Recommended External Oscillator Circuits

The oscillator circuit, a Pierce oscillator, is designed to work with both, an external crystal oscillator or an external stable clock source. It basically consists of an inverting amplifier and a feedback element with XTAL1 as input, and XTAL2 as output.

When using a crystal, a proper external oscillator circuitry must be connected to both pins, XTAL1 and XTAL2. The crystal frequency can be within the range of 4 MHz to 12 MHz. Additionally, it is necessary to have two load capacitances  $C_{X1}$  and  $C_{X2}$ , and depending on the crystal type, a series resistor  $R_{X2}$ , to limit the current. A test resistor  $R_Q$  may be temporarily inserted to measure the oscillation allowance (negative resistance) of the oscillator circuitry.  $R_Q$  values are typically specified by the crystal vendor. The  $C_{X1}$  and  $C_{X2}$  values shown in **Figure 24** can be used as starting points for the negative resistance evaluation and for non-productive systems. The exact values and related operating range are dependent on the crystal frequency and have to be determined and optimized together with the crystal vendor using the negative resistance method. Oscillation measurement with the final target system is strongly recommended to verify the input amplitude at XTAL1 and to determine the actual oscillation allowance (margin negative resistance) for the oscillator-crystal system.

When using an external clock signal, the signal must be connected to XTAL1. XTAL2 is left open (unconnected).

The oscillator can also be used in combination with a ceramic resonator. The final circuitry must also be verified by the resonator vendor.

**Figure 24** shows the recommended external oscillator circuitries for both operating modes, external crystal mode and external input clock mode.

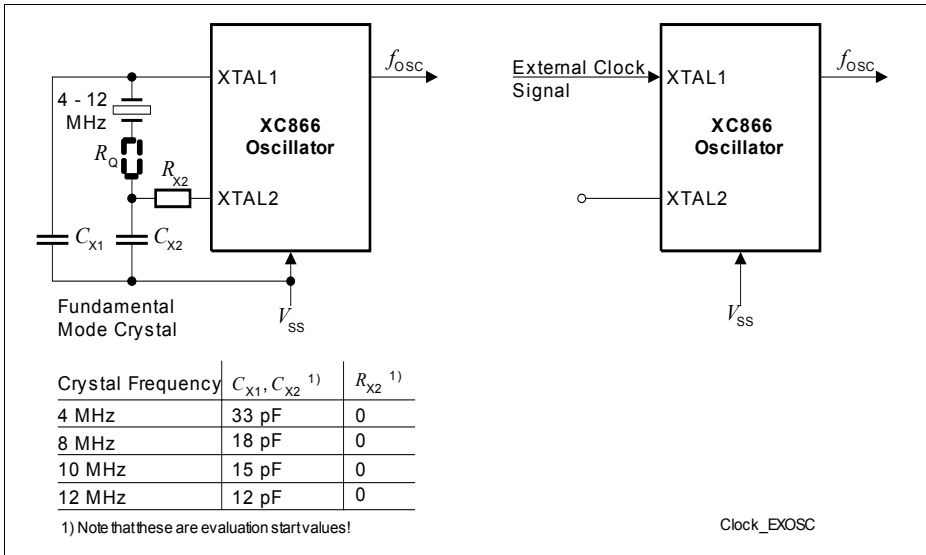

**Figure 24 External Oscillator Circuitries**

*Note: For crystal operation, it is strongly recommended to measure the negative resistance in the final target system (layout) to determine the optimum parameters for the oscillator operation. Please refer to the minimum and maximum values of the negative resistance specified by the crystal supplier.*

### 3.8.2 Clock Management

The CGU generates all clock signals required within the microcontroller from a single clock,  $f_{sys}$ . During normal system operation, the typical frequencies of the different modules are as follow:

- CPU clock: CCLK, SCLK = 26.7 MHz
- CCU6 clock: FCLK = 26.7 MHz
- Other peripherals: PCLK = 26.7 MHz
- Flash Interface clock: CCLK3 = 80 MHz and CCLK = 26.7 MHz

In addition, different clock frequency can output to pin CLKOUT(P0.0). The clock output frequency can further be divided by 2 using toggle latch (bit TLEN is set to 1), the resulting output frequency has 50% duty cycle. **Figure 25** shows the clock distribution of the SAA-XC866.

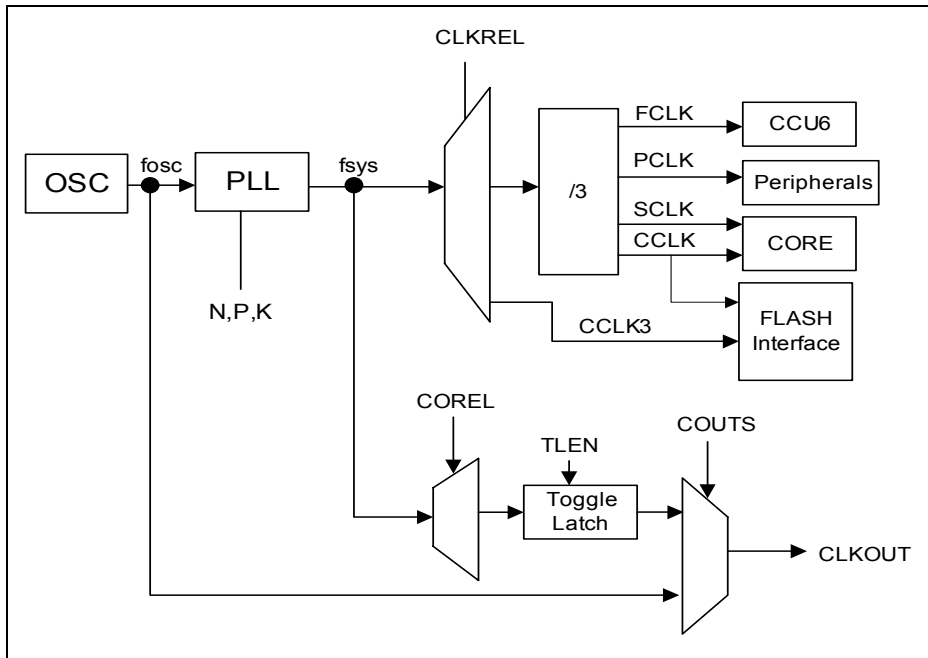

Figure 25 Clock Generation from  $f_{sys}$



**Functional Description**

For power saving purposes, the clocks may be disabled or slowed down according to [Table 23](#).

**Table 23** System frequency ( $f_{\text{sys}} = 80 \text{ MHz}$ )

| <b>Power Saving Mode</b> | <b>Action</b>   |
|--------------------------|---|
| Idle                     | Clock to the CPU is disabled.   |
| Slow-down                | Clocks to the CPU and all the peripherals, including CCU6, are divided by a common programmable factor defined by bit field CMCON.CLKREL. |
| Power-down               | Oscillator and PLL are switched off.  |

### 3.9 Power Saving Modes

The power saving modes of the SAA-XC866 provide flexible power consumption through a combination of techniques, including:

- Stopping the CPU clock
- Stopping the clocks of individual system components
- Reducing clock speed of some peripheral components
- Power-down of the entire system with fast restart capability

After a reset, the active mode (normal operating mode) is selected by default (see [Figure 26](#)) and the system runs in the main system clock frequency. From active mode, different power saving modes can be selected by software. They are:

- Idle mode
- Slow-down mode
- Power-down mode

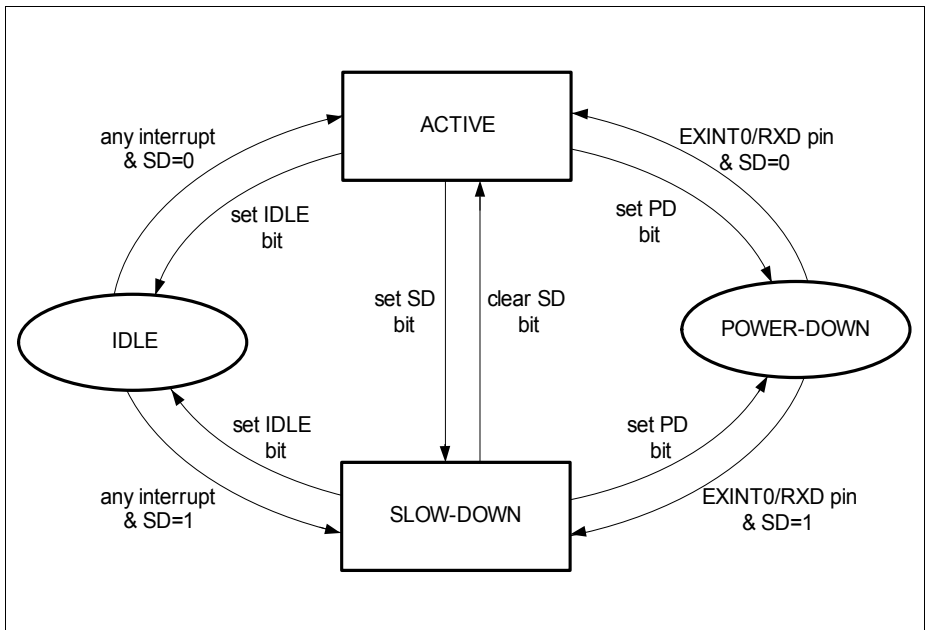

Figure 26 Transition between Power Saving Modes

### 3.10 Watchdog Timer

The Watchdog Timer (WDT) provides a highly reliable and secure way to detect and recover from software or hardware failures. The WDT is reset at a regular interval that is predefined by the user. The CPU must service the WDT within this interval to prevent the WDT from causing an SAA-XC866 system reset. Hence, routine service of the WDT confirms that the system is functioning properly. This ensures that an accidental malfunction of the SAA-XC866 will be aborted in a user-specified time period. In debug mode, the WDT is suspended and stops counting. Therefore, there is no need to refresh the WDT during debugging.

**Features:**

- 16-bit Watchdog Timer
- Programmable reload value for upper 8 bits of timer
- Programmable window boundary
- Selectable input frequency of  $f_{PCLK}/2$  or  $f_{PCLK}/128$
- Time-out detection with NMI generation and reset prewarning activation (after which a system reset will be performed)

The WDT is a 16-bit timer incremented by a count rate of  $f_{PCLK}/2$  or  $f_{PCLK}/128$ . This 16-bit timer is realized as two concatenated 8-bit timers. The upper 8 bits of the WDT can be preset to a user-programmable value via a watchdog service access in order to modify the watchdog expire time period. The lower 8 bits are reset on each service access. **Figure 27** shows the block diagram of the WDT unit.

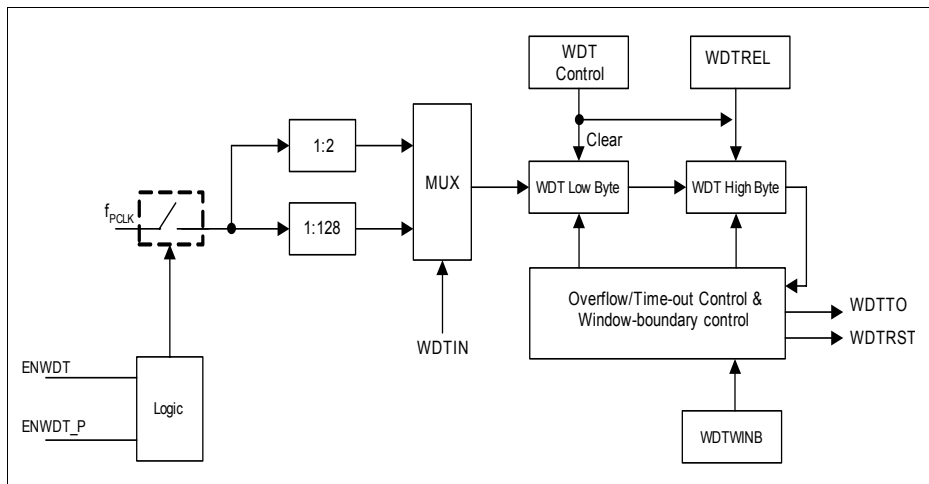

**Figure 27 WDT Block Diagram**

**Functional Description**

If the WDT is not serviced before the timer overflow, a system malfunction is assumed. As a result, the WDT NMI is triggered (assert WDTTO) and the reset prewarning is entered. The prewarning period lasts for 30<sub>H</sub> count, after which the system is reset (assert WDRST).

The WDT has a “programmable window boundary” which disallows any refresh during the WDT’s count-up. A refresh during this window boundary constitutes an invalid access to the WDT, causing the reset prewarning to be entered but without triggering the WDT NMI. The system will still be reset after the prewarning period is over. The window boundary is from 0000<sub>H</sub> to the value obtained from the concatenation of WDTWINB and 00<sub>H</sub>.

After being serviced, the WDT continues counting up from the value (<WDTREL> \* 2<sup>8</sup>). The time period for an overflow of the WDT is programmable in two ways:

- the input frequency to the WDT can be selected to be either  $f_{PCLK}/2$  or  $f_{PCLK}/128$
- the reload value WDTREL for the high byte of WDT can be programmed in register WDTREL

The period, P<sub>WDT</sub>, between servicing the WDT and the next overflow can be determined by the following formula:

$$P_{WDT} = \frac{2^{(1 + WDTIN \times 6)} \times (2^{16} - WDTREL \times 2^8)}{f_{PCLK}}$$

If the Window-Boundary Refresh feature of the WDT is enabled, the period P<sub>WDT</sub> between servicing the WDT and the next overflow is shortened if WDTWINB is greater than WDTREL, see [Figure 28](#). This period can be calculated using the same formula by replacing WDTREL with WDTWINB. For this feature to be useful, WDTWINB should not be smaller than WDTREL.

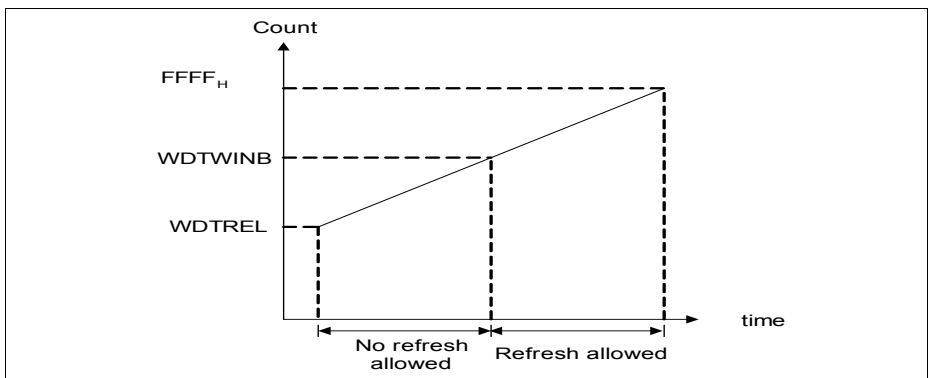

**Figure 28 WDT Timing Diagram**

**Functional Description**

**Table 24** lists the possible watchdog time range that can be achieved for different module clock frequencies . Some numbers are rounded to 3 significant digits.

**Table 24 Watchdog Time Ranges**

| Reload value<br>in WDTREL | Prescaler for $f_{PCLK}$ |                 |
|---------------------------|--------------------------|-----------------|
|                           | 2 (WDTIN = 0)            | 128 (WDTIN = 1) |
|                           | <b>26.7 MHz</b>          | <b>26.7 MHz</b> |
| FF <sub>H</sub>           | 19.2 $\mu$ s             | 1.23 ms         |
| 7F <sub>H</sub>           | 2.48 ms                  | 159 ms          |
| 00 <sub>H</sub>           | 4.92 ms                  | 315 ms          |

### 3.11 Universal Asynchronous Receiver/Transmitter

The Universal Asynchronous Receiver/Transmitter (UART) provides a full-duplex asynchronous receiver/transmitter, i.e., it can transmit and receive simultaneously. It is also receive-buffered, i.e., it can commence reception of a second byte before a previously received byte has been read from the receive register. However, if the first byte still has not been read by the time reception of the second byte is complete, one of the bytes will be lost.

#### Features:

- Full-duplex asynchronous modes
  - 8-bit or 9-bit data frames, LSB first
  - fixed or variable baud rate
- Receive buffered
- Multiprocessor communication
- Interrupt generation on the completion of a data transmission or reception

The UART can operate in four asynchronous modes as shown in [Table 25](#). Data is transmitted on TXD and received on RXD.

**Table 25 UART Modes**

| Operating Mode               | Baud Rate                      |
|------------------------------|--------------------------------|
| Mode 0: 8-bit shift register | $f_{PCLK}/2$                   |
| Mode 1: 8-bit shift UART     | Variable                       |
| Mode 2: 9-bit shift UART     | $f_{PCLK}/32$ or $f_{PCLK}/64$ |
| Mode 3: 9-bit shift UART     | Variable                       |

There are several ways to generate the baud rate clock for the serial port, depending on the mode in which it is operating. In mode 0, the baud rate for the transfer is fixed at  $f_{PCLK}/2$ . In mode 2, the baud rate is generated internally based on the UART input clock and can be configured to either  $f_{PCLK}/32$  or  $f_{PCLK}/64$ . The variable baud rate is set by either the underflow rate on the dedicated baud-rate generator, or by the overflow rate on Timer 1.



**Functional Description**

- 8-bit reload value (BR\_VALUE) for the baud rate timer defined by register BG

The following formulas calculate the final baud rate without and with the fractional divider respectively:

$$\text{baud rate} = \frac{f_{\text{PCLK}}}{16 \times 2^{\text{BRPRE}} \times (\text{BR\_VALUE} + 1)} \quad \text{where } 2^{\text{BRPRE}} \times (\text{BR\_VALUE} + 1) > 1$$

$$\text{baud rate} = \frac{f_{\text{PCLK}}}{16 \times 2^{\text{BRPRE}} \times (\text{BR\_VALUE} + 1)} \times \frac{\text{STEP}}{256}$$

The maximum baud rate that can be generated is limited to  $f_{\text{PCLK}}/32$ . Hence, for a module clock of 26.7 MHz, the maximum achievable baud rate is 0.83 MBaud.

Standard LIN protocol can support a maximum baud rate of 20kHz, the baud rate accuracy is not critical and the fractional divider can be disabled. Only the prescaler is used for auto baud rate calculation. For LIN fast mode, which supports the baud rate of 20kHz to 115.2kHz, the higher baud rates require the use of the fractional divider for greater accuracy.

**Table 26** lists the various commonly used baud rates with their corresponding parameter settings and deviation errors. The fractional divider is disabled and a module clock of 26.7 MHz is used.

**Table 26 Typical Baud rates for UART with Fractional Divider disabled**

| Baud rate  | Prescaling Factor ( $2^{\text{BRPRE}}$ ) | Reload Value (BR_VALUE + 1) | Deviation Error |
|------------|--|-----------------------------|-----------------|
| 19.2 kBaud | 1 (BRPRE=000 <sub>B</sub> )              | 87 (57 <sub>H</sub> )       | -0.22 %         |
| 9600 Baud  | 1 (BRPRE=000 <sub>B</sub> )              | 174 (AE <sub>H</sub> )      | -0.22 %         |
| 4800 Baud  | 2 (BRPRE=001 <sub>B</sub> )              | 174 (AE <sub>H</sub> )      | -0.22 %         |
| 2400 Baud  | 4 (BRPRE=010 <sub>B</sub> )              | 174 (AE <sub>H</sub> )      | -0.22 %         |

The fractional divider allows baud rates of higher accuracy (lower deviation error) to be generated. **Table 27** lists the resulting deviation errors from generating a baud rate of 115.2 kHz, using different module clock frequencies. The fractional divider is enabled (fractional divider mode) and the corresponding parameter settings are shown.



**Table 27      Deviation Error for UART with Fractional Divider enabled**

| <b>f<sub>PCLK</sub></b> | <b>Prescaling Factor<br/>(2<sup>BRPRE</sup>)</b> | <b>Reload Value<br/>(BR_VALUE + 1)</b> | <b>STEP</b>            | <b>Deviation<br/>Error</b> |
|-------------------------|--|--|------------------------|----------------------------|
| 26.67 MHz               | 1  | 10 (A <sub>H</sub> )                   | 177 (B1 <sub>H</sub> ) | +0.03 %                    |
| 13.33 MHz               | 1  | 7 (7 <sub>H</sub> )                    | 248 (F8 <sub>H</sub> ) | +0.11 %                    |
| 6.67 MHz                | 1  | 3 (3 <sub>H</sub> )                    | 212 (D4 <sub>H</sub> ) | -0.16 %                    |

### 3.11.2 Baud Rate Generation using Timer 1

In UART modes 1 and 3, Timer 1 can be used for generating the variable baud rates. In theory, this timer could be used in any of its modes. But in practice, it should be set into auto-reload mode (Timer 1 mode 2), with its high byte set to the appropriate value for the required baud rate. The baud rate is determined by the Timer 1 overflow rate and the value of SMOD as follows:

$$\text{Mode 1, 3 baud rate} = \frac{2^{\text{SMOD}} \times f_{\text{PCLK}}}{32 \times 2 \times (256 - \text{TH1})} \quad [3.1]$$

### 3.12 Normal Divider Mode (8-bit Auto-reload Timer)

Setting bit FDM in register FDCON to 1 configures the fractional divider to normal divider mode, while at the same time disables baud rate generation (see [Figure 29](#)). Once the fractional divider is enabled (FDEN = 1), it functions as an 8-bit auto-reload timer (with no relation to baud rate generation) and counts up from the reload value with each input clock pulse. Bit field RESULT in register FDRES represents the timer value, while bit field STEP in register FDSTEP defines the reload value. At each timer overflow, an overflow flag (FDCON.NDOV) will be set and an interrupt request generated. This gives an output clock  $f_{\text{MOD}}$  that is 1/n of the input clock  $f_{\text{DIV}}$ , where n is defined by 256 - STEP.

The output frequency in normal divider mode is derived as follows:

$$f_{\text{MOD}} = f_{\text{DIV}} \times \frac{1}{256 - \text{STEP}} \quad [3.2]$$

### 3.13 LIN Protocol

The UART can be used to support the Local Interconnect Network (LIN) protocol for both master and slave operations. The LIN baud rate detection feature provides the capability to detect the baud rate within LIN protocol using Timer 2. This allows the UART to be synchronized to the LIN baud rate for data transmission and reception.

LIN is a holistic communication concept for local interconnected networks in vehicles. The communication is based on the SCI (UART) data format, a single-master/multiple-slave concept, a clock synchronization for nodes without stabilized time base. An attractive feature of LIN is self-synchronization of the slave nodes without a crystal or ceramic resonator, which significantly reduces the cost of hardware platform. Hence, the baud rate must be calculated and returned with every message frame.

The structure of a LIN frame is shown in **Figure 30**. The frame consists of the:

- header, which comprises a Break (13-bit time low), Synch Byte (55<sub>H</sub>), and ID field
- response time
- data bytes (according to UART protocol)
- checksum

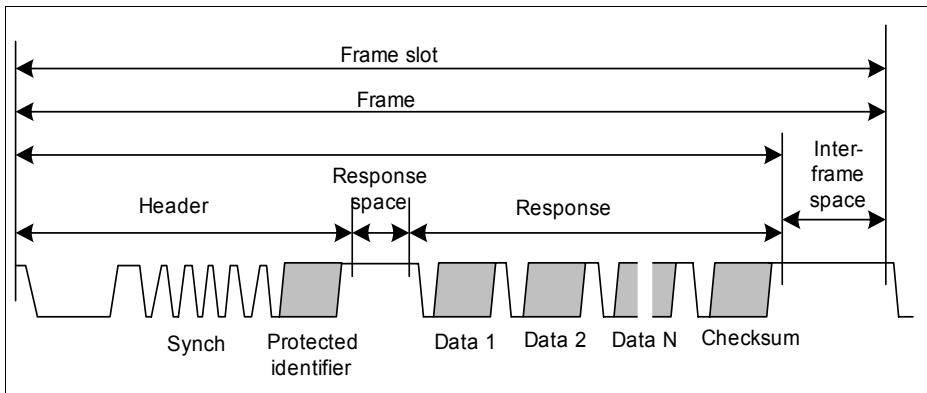

**Figure 30 Structure of LIN Frame**

#### 3.13.1 LIN Header Transmission

LIN header transmission is only applicable in master mode. In the LIN communication, a master task decides when and which frame is to be transferred on the bus. It also identifies a slave task to provide the data transported by each frame. The information needed for the handshaking between the master and slave tasks is provided by the master task through the header portion of the frame.

The header consists of a break and synch pattern followed by an identifier. Among these three fields, only the break pattern cannot be transmitted as a normal 8-bit UART data.

---

**Functional Description**

The break must contain a dominant value of 13 bits or more to ensure proper synchronization of slave nodes.

In the LIN communication, a slave task is required to be synchronized at the beginning of the protected identifier field of frame. For this purpose, every frame starts with a sequence consisting of a break field followed by a synch byte field. This sequence is unique and provides enough information for any slave task to detect the beginning of a new frame and be synchronized at the start of the identifier field.

Upon entering LIN communication, a connection is established and the transfer speed (baud rate) of the serial communication partner (host) is automatically synchronized in the following steps:

STEP 1: Initialize interface for reception and timer for baud rate measurement

STEP 2: Wait for an incoming LIN frame from host

STEP 3: Synchronize the baud rate to the host

STEP 4: Enter for Master Request Frame or for Slave Response Frame

*Note: Re-synchronization and setup of baud rate are always done for **every** Master Request Header or Slave Response Header LIN frame.*

### 3.14 High-Speed Synchronous Serial Interface

The High-Speed Synchronous Serial Interface (SSC) supports full-duplex and half-duplex synchronous communication. The serial clock signal can be generated by the SSC internally (master mode), using its own 16-bit baud-rate generator, or can be received from an external master (slave mode). Data width, shift direction, clock polarity and phase are programmable. This allows communication with SPI-compatible devices or devices using other synchronous serial interfaces.

#### Features:

- Master and slave mode operation
  - Full-duplex or half-duplex operation
- Transmit and receive buffered
- Flexible data format
  - Programmable number of data bits: 2 to 8 bits
  - Programmable shift direction: LSB or MSB shift first
  - Programmable clock polarity: idle low or high state for the shift clock
  - Programmable clock/data phase: data shift with leading or trailing edge of the shift clock
- Variable baud rate
- Compatible with Serial Peripheral Interface (SPI)
- Interrupt generation
  - On a transmitter empty condition
  - On a receiver full condition
  - On an error condition (receive, phase, baud rate, transmit error)

**Functional Description**

Data is transmitted or received on lines TXD and RXD, which are normally connected to the pins MTSR (Master Transmit/Slave Receive) and MRST (Master Receive/Slave Transmit). The clock signal is output via line MS\_CLK (Master Serial Shift Clock) or input via line SS\_CLK (Slave Serial Shift Clock). Both lines are normally connected to the pin SCLK. Transmission and reception of data are double-buffered.

**Figure 31** shows the block diagram of the SSC.

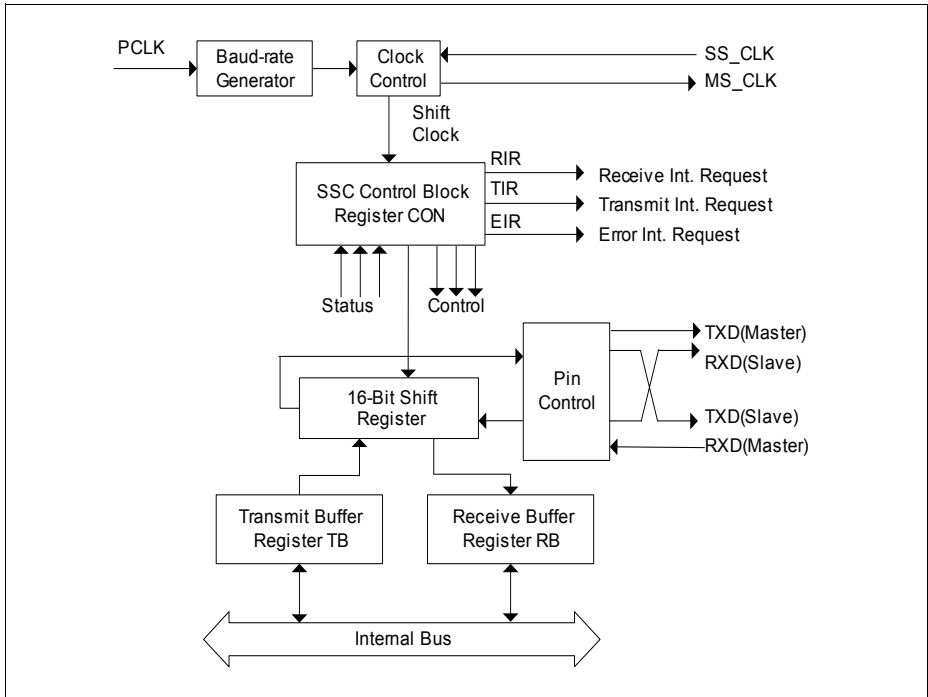

**Figure 31 SSC Block Diagram**

### 3.15 Timer 0 and Timer 1

Timers 0 and 1 are count-up timers which are incremented every machine cycle, or in terms of the input clock, every 2 PCLK cycles. They are fully compatible and can be configured in four different operating modes for use in a variety of applications, see [Table 28](#). In modes 0, 1 and 2, the two timers operate independently, but in mode 3, their functions are specialized.

**Table 28 Timer 0 and Timer 1 Modes**

| Mode     | Operation   |
|----------|---|
| <b>0</b> | <b>13-bit timer</b><br>The timer is essentially an 8-bit counter with a divide-by-32 prescaler. This mode is included solely for compatibility with Intel 8048 devices.           |
| <b>1</b> | <b>16-bit timer</b><br>The timer registers, TLx and THx, are concatenated to form a 16-bit counter.   |
| <b>2</b> | <b>8-bit timer with auto-reload</b><br>The timer register TLx is reloaded with a user-defined 8-bit value in THx upon overflow.   |
| <b>3</b> | <b>Timer 0 operates as two 8-bit timers</b><br>The timer registers, TL0 and TH0, operate as two separate 8-bit counters. Timer 1 is halted and retains its count even if enabled. |

### 3.16 Timer 2

Timer 2 is a 16-bit general purpose timer (THL2) that has two modes of operation, a 16-bit auto-reload mode and a 16-bit one channel capture mode. If the prescaler is disabled, Timer 2 counts with an input clock of PCLK/12. Timer 2 continues counting as long as it is enabled.

**Table 29 Timer 2 Modes**

| Mode            | Description   |
|-----------------|---|
| Auto-reload     | <p><b>Up/Down Count Disabled</b></p> <ul style="list-style-type: none"> <li>• Count up only</li> <li>• Start counting from 16-bit reload value, overflow at FFFF<sub>H</sub></li> <li>• Reload event configurable for trigger by overflow condition only, or by negative/positive edge at input pin T2EX as well</li> <li>• Programmable reload value in register RC2</li> <li>• Interrupt is generated with reload event</li> </ul>  |
|                 | <p><b>Up/Down Count Enabled</b></p> <ul style="list-style-type: none"> <li>• Count up or down, direction determined by level at input pin T2EX</li> <li>• No interrupt is generated</li> <li>• Count up               <ul style="list-style-type: none"> <li>– Start counting from 16-bit reload value, overflow at FFFF<sub>H</sub></li> <li>– Reload event triggered by overflow condition</li> <li>– Programmable reload value in register RC2</li> </ul> </li> <li>• Count down               <ul style="list-style-type: none"> <li>– Start counting from FFFF<sub>H</sub>, underflow at value defined in register RC2</li> <li>– Reload event triggered by underflow condition</li> <li>– Reload value fixed at FFFF<sub>H</sub></li> </ul> </li> </ul> |
| Channel capture | <ul style="list-style-type: none"> <li>• Count up only</li> <li>• Start counting from 0000<sub>H</sub>, overflow at FFFF<sub>H</sub></li> <li>• Reload event triggered by overflow condition</li> <li>• Reload value fixed at 0000<sub>H</sub></li> <li>• Capture event triggered by falling/rising edge at pin T2EX</li> <li>• Captured timer value stored in register RC2</li> <li>• Interrupt is generated with reload or capture event</li> </ul>   |



### 3.17 Capture/Compare Unit 6

The Capture/Compare Unit 6 (CCU6) provides two independent timers (T12, T13), which can be used for Pulse Width Modulation (PWM) generation, especially for AC-motor control. The CCU6 also supports special control modes for block commutation and multi-phase machines.

The timer T12 can function in capture and/or compare mode for its three channels. The timer T13 can work in compare mode only.

The multi-channel control unit generates output patterns, which can be modulated by T12 and/or T13. The modulation sources can be selected and combined for the signal modulation.

#### Timer T12 Features:

- Three capture/compare channels, each channel can be used either as a capture or as a compare channel
- Supports generation of a three-phase PWM (six outputs, individual signals for highside and lowside switches)
- 16-bit resolution, maximum count frequency = peripheral clock frequency
- Dead-time control for each channel to avoid short-circuits in the power stage
- Concurrent update of the required T12/13 registers
- Generation of center-aligned and edge-aligned PWM
- Supports single-shot mode
- Supports many interrupt request sources
- Hysteresis-like control mode

#### Timer T13 Features:

- One independent compare channel with one output
- 16-bit resolution, maximum count frequency = peripheral clock frequency
- Can be synchronized to T12
- Interrupt generation at period-match and compare-match
- Supports single-shot mode

#### Additional Features:

- Implements block commutation for Brushless DC-drives
- Position detection via Hall-sensor pattern
- Automatic rotational speed measurement for block commutation
- Integrated error handling
- Fast emergency stop without CPU load via external signal ( $\overline{\text{CTRAP}}$ )
- Control modes for multi-channel AC-drives
- Output levels can be selected and adapted to the power stage

Functional Description

The block diagram of the CCU6 module is shown in **Figure 32**.

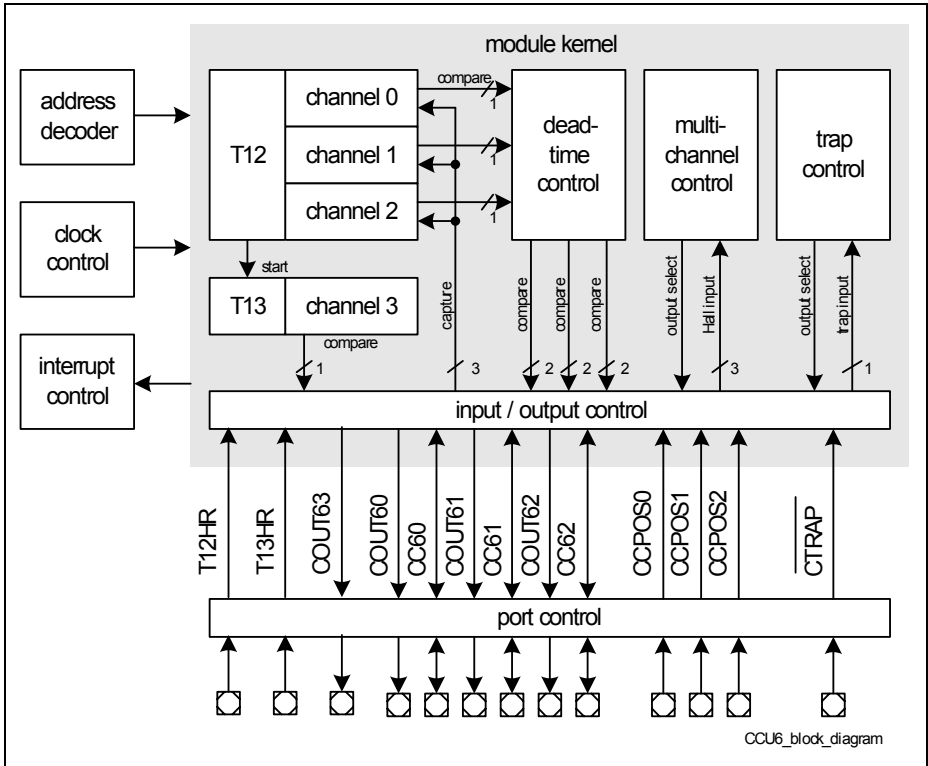

Figure 32 CCU6 Block Diagram

### 3.18 Analog-to-Digital Converter

The SAA-XC866 includes a high-performance 10-bit Analog-to-Digital Converter (ADC) with eight multiplexed analog input channels. The ADC uses a successive approximation technique to convert the analog voltage levels from up to eight different sources. The analog input channels of the ADC are available at Port 2.

#### Features:

- Successive approximation
- 8-bit or 10-bit resolution  
(TUE of  $\pm 1$  LSB and  $\pm 2$  LSB, respectively)
- Eight analog channels
- Four independent result registers
- Result data protection for slow CPU access  
(wait-for-read mode)
- Single conversion mode
- Autoscan functionality
- Limit checking for conversion results
- Data reduction filter  
(accumulation of up to 2 conversion results)
- Two independent conversion request sources with programmable priority
- Selectable conversion request trigger
- Flexible interrupt generation with configurable service nodes
- Programmable sample time
- Programmable clock divider
- Cancel/restart feature for running conversions
- Integrated sample and hold circuitry
- Compensation of offset errors
- Low power modes

### 3.18.1 ADC Clocking Scheme

A common module clock  $f_{ADC}$  generates the various clock signals used by the analog and digital parts of the ADC module:

- $f_{ADCA}$  is input clock for the analog part.
- $f_{ADCI}$  is internal clock for the analog part (defines the time base for conversion length and the sample time). This clock is generated internally in the analog part, based on the input clock  $f_{ADCA}$  to generate a correct duty cycle for the analog components.
- $f_{ADCD}$  is input clock for the digital part.

The internal clock for the analog part  $f_{ADCI}$  is limited to a maximum frequency of 10 MHz. Therefore, the ADC clock prescaler must be programmed to a value that ensures  $f_{ADCI}$  does not exceed 10 MHz. The prescaler ratio is selected by bit field CTC in register GLOBCTR. A prescaling ratio of 32 can be selected when the maximum performance of the ADC is not required.

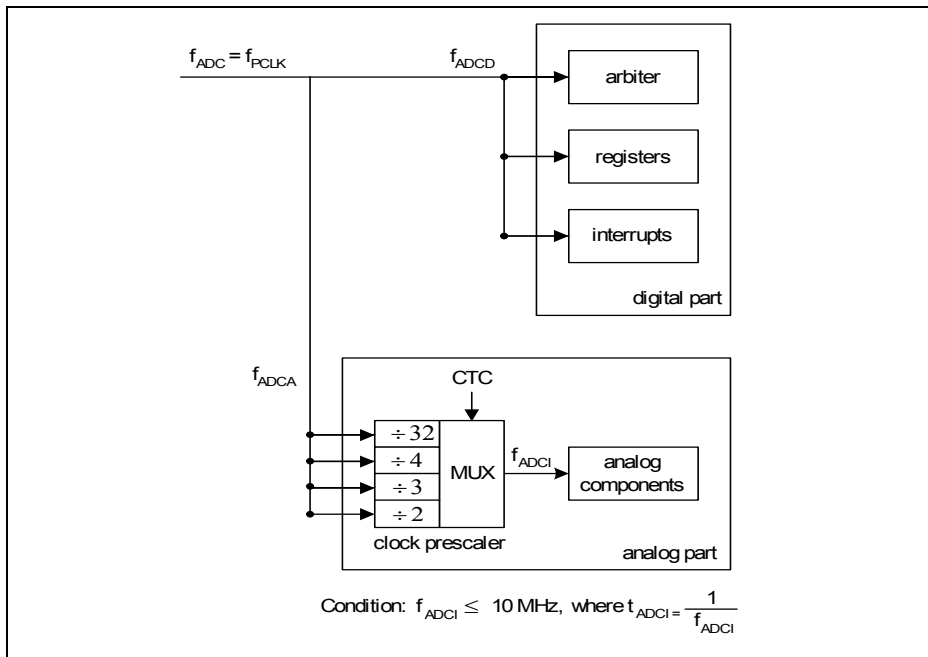

Figure 33 ADC Clocking Scheme

**Functional Description**

For module clock  $f_{ADC} = 26.7$  MHz, the analog clock  $f_{ADCI}$  frequency can be selected as shown in **Table 30**.

**Table 30  $f_{ADCI}$  Frequency Selection**

| Module Clock $f_{ADC}$ | CTC                       | Prescaling Ratio | Analog Clock $f_{ADCI}$ |
|------------------------|---------------------------|------------------|-------------------------|
| 26.7 MHz               | 00 <sub>B</sub>           | ÷ 2              | 13.3 MHz (N.A)          |
|                        | 01 <sub>B</sub>           | ÷ 3              | 8.9 MHz                 |
|                        | 10 <sub>B</sub>           | ÷ 4              | 6.7 MHz                 |
|                        | 11 <sub>B</sub> (default) | ÷ 32             | 833.3 kHz               |

As  $f_{ADCI}$  cannot exceed 10 MHz, bit field CTC should not be set to 00<sub>B</sub> when  $f_{ADC}$  is 26.7 MHz. During slow-down mode where  $f_{ADC}$  may be reduced to 13.3 MHz, 6.7 MHz etc., CTC can be set to 00<sub>B</sub> as long as the divided analog clock  $f_{ADCI}$  does not exceed 10 MHz. However, it is important to note that the conversion error could increase due to loss of charges on the capacitors, if  $f_{ADC}$  becomes too low during slow-down mode.

**3.18.2 ADC Conversion Sequence**

The analog-to-digital conversion procedure consists of the following phases:

- Synchronization phase ( $t_{SYN}$ )
- Sample phase ( $t_S$ )
- Conversion phase
- Write result phase ( $t_{WR}$ )

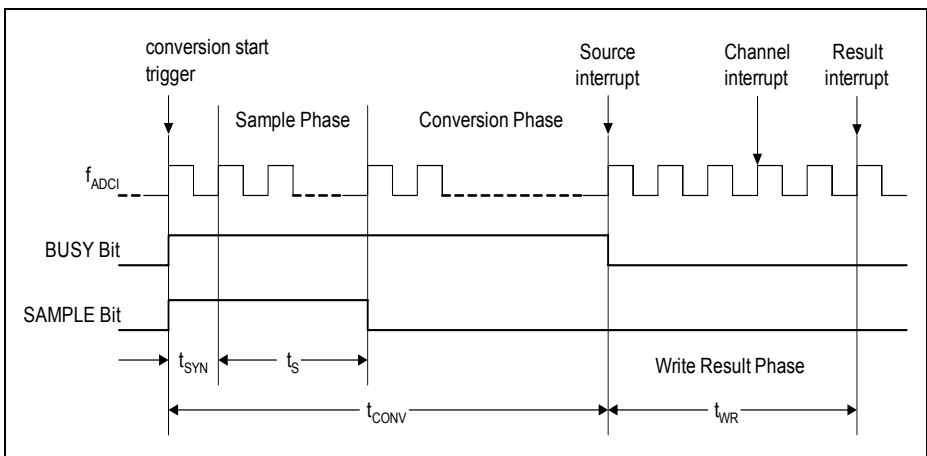

**Figure 34 ADC Conversion Timing**

### 3.19 On-Chip Debug Support

The On-Chip Debug Support (OCDS) provides the basic functionality required for the software development and debugging of XC800-based systems.

The OCDS design is based on these principles:

- use the built-in debug functionality of the XC800 Core
- add a minimum of hardware overhead
- provide support for most of the operations by a Monitor Program
- use standard interfaces to communicate with the Host (a Debugger)

#### Features:

- Set breakpoints on instruction address and within a specified address range
- Set breakpoints on internal RAM address
- Support unlimited software breakpoints in Flash/RAM code region
- Process external breaks
- Step through the program code

The OCDS functional blocks are shown in **Figure 35**. The Monitor Mode Control (MMC) block at the center of OCDS system brings together control signals and supports the overall functionality. The MMC communicates with the XC800 Core, primarily via the Debug Interface, and also receives reset and clock signals. After processing memory address and control signals from the core, the MMC provides proper access to the dedicated extra-memories: a Monitor ROM (holding the code) and a Monitor RAM (for work-data and Monitor-stack). The OCDS system is accessed through the JTAG<sup>1)</sup>, which is an interface dedicated exclusively for testing and debugging activities and is not normally used in an application. The dedicated MBC pin is used for external configuration and debugging control.

*Note: All the debug functionality described here can normally be used only after SAA-XC866 has been started in OCDS mode.*

<sup>1)</sup> The pins of the JTAG port can be assigned to either Port 0 (primary) or Ports 1 and 2 (secondary). User must set the JTAG pins (TCK and TDI) as input during connection with the OCDS system.

Functional Description

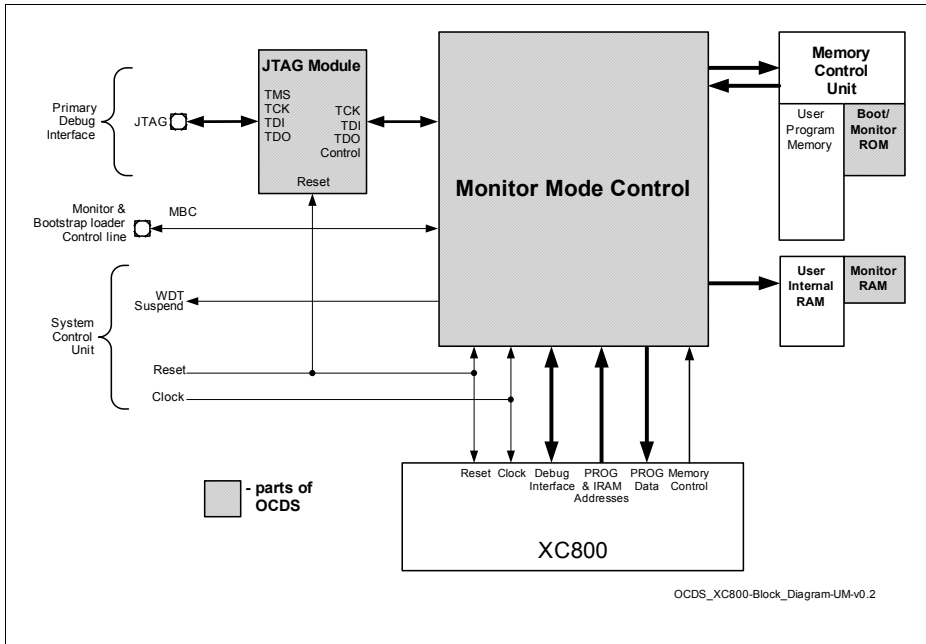

Figure 35 OCDS Block Diagram

### 3.19.1 JTAG ID Register

This is a read-only register located inside the JTAG module, and is used to recognize the device(s) connected to the JTAG interface. Its content is shifted out when INSTRUCTION register contains the IDCODE command (opcode 04<sub>H</sub>), and the same is also true immediately after reset.

The JTAG ID register contents for the SAA-XC866 devices are given in [Table 31](#).

Table 31 JTAG ID Summary

| Device Type | Device Name     | JTAG ID                |
|-------------|-----------------|------------------------|
| Flash       | SAA-XC866L-4FRA | 1010 0083 <sub>H</sub> |
|             | SAA-XC866-4FRA  | 100F 5083 <sub>H</sub> |
|             | SAA-XC866L-2FRA | 1010 2083 <sub>H</sub> |
|             | SAA-XC866-2FRA  | 1010 1083 <sub>H</sub> |
|             | SAA-XC866L-1FRA | 1013 8083 <sub>H</sub> |
|             | SAA-XC866-1FRA  | 1013 8083 <sub>H</sub> |

**Table 31 JTAG ID Summary**

|     |                 |                        |
|-----|-----------------|------------------------|
| ROM | SAA-XC866L-4RRA | 1013 9083 <sub>H</sub> |
|     | SAA-XC866-4RRA  | 1013 9083 <sub>H</sub> |
|     | SAA-XC866L-2RRA | 1013 9083 <sub>H</sub> |
|     | SAA-XC866-2RRA  | 1013 9083 <sub>H</sub> |

### 3.20 Identification Register

The SAA-XC866 identity register is located at Page 1 of address B3<sub>H</sub>.

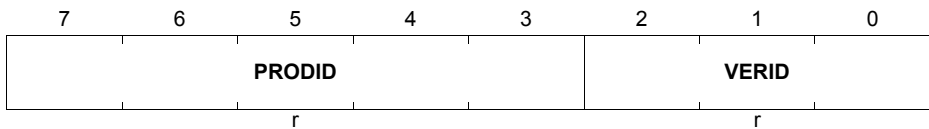
**ID**
**Identity Register**
**Reset Value: 0000 0010<sub>B</sub>**

| Field         | Bits  | Type | Description                             |
|---------------|-------|------|---|
| <b>VERID</b>  | [2:0] | r    | <b>Version ID</b><br>010 <sub>B</sub>   |
| <b>PRODID</b> | [7:3] | r    | <b>Product ID</b><br>00000 <sub>B</sub> |



## 4 Electrical Parameters

**Chapter 4** provides the characteristics of the electrical parameters which are implementation-specific for the SAA-XC866.

### 4.1 General Parameters

The general parameters are described here to aid the users in interpreting the parameters mainly in [Section 4.2](#) and [Section 4.3](#).

#### 4.1.1 Parameter Interpretation

The parameters listed in this section represent partly the characteristics of the SAA-XC866 and partly its requirements on the system. To aid interpreting the parameters easily when evaluating them for a design, they are indicated by the abbreviations in the "Symbol" column:

- **CC**  
These parameters indicate **C**ontroller **C**haracteristics, which are distinctive features of the SAA-XC866 and must be regarded for a system design.
- **SR**  
These parameters indicate **S**ystem **R**equirements, which must be provided by the microcontroller system in which the SAA-XC866 is designed in.

### 4.1.2 Absolute Maximum Rating

Maximum ratings are the extreme limits to which the SAA-XC866 can be subjected to without permanent damage.

**Table 32 Absolute Maximum Rating Parameters**

| Parameter  | Symbol           | Limit Values |                           | Unit | Notes             |
|--|------------------|--------------|---------------------------|------|-------------------|
|  |                  | min.         | max.                      |      |                   |
| Ambient temperature  | $T_A$            | -40          | 140                       | °C   | under bias        |
| Storage temperature  | $T_{ST}$         | -65          | 150                       | °C   |                   |
| Junction temperature   | $T_J$            | -40          | 150                       | °C   | under bias        |
| Voltage on power supply pin with respect to $V_{SS}$         | $V_{DDP}$        | -0.5         | 6                         | V    |                   |
| Voltage on core supply pin with respect to $V_{SS}$          | $V_{DDC}$        | -0.5         | 3.25                      | V    |                   |
| Voltage on any pin with respect to $V_{SS}$                  | $V_{IN}$         | -0.5         | $V_{DDP} + 0.5$ or max. 6 | V    | Whatever is lower |
| Input current on any pin during overload condition           | $I_{IN}$         | -10          | 10                        | mA   |                   |
| Absolute sum of all input currents during overload condition | $\Sigma I_{IN} $ | –            | 50                        | mA   |                   |

*Note: Stresses above those listed under “Absolute Maximum Ratings” may cause permanent damage to the device. This is a stress rating only and functional operation of the device at these or any other conditions above those indicated in the operational sections of this specification is not implied. Exposure to absolute maximum rating conditions for extended periods may affect device reliability. During absolute maximum rating overload conditions ( $V_{IN} > V_{DDP}$  or  $V_{IN} < V_{SS}$ ) the voltage on  $V_{DDP}$  pin with respect to ground ( $V_{SS}$ ) must not exceed the values defined by the absolute maximum ratings.*

### 4.1.3 Operating Conditions

The following operating conditions must not be exceeded in order to ensure correct operation of the SAA-XC866. All parameters mentioned in the following table refer to these operating conditions, unless otherwise noted.

**Table 33 Operating Condition Parameters**

| Parameter                            | Symbol    | Limit Values |      | Unit | Notes/<br>Conditions |
|--------------------------------------|-----------|--------------|------|------|----------------------|
|                                      |           | min.         | max. |      |                      |
| Digital power supply voltage         | $V_{DDP}$ | 4.5          | 5.5  | V    | 5V Device            |
| Digital ground voltage               | $V_{SS}$  | 0            |      | V    |                      |
| Digital core supply voltage          | $V_{DDC}$ | 2.3          | 2.7  | V    |                      |
| System Clock Frequency <sup>1)</sup> | $f_{SYS}$ | 74           | 86   | MHz  |                      |
| Ambient temperature                  | $T_A$     | -40          | 140  | °C   | SAA-XC866...         |

<sup>1)</sup>  $f_{SYS}$  is the PLL output clock. During normal operating mode, CPU clock is  $f_{SYS} / 3$ . Please refer to [Figure 25](#) for detailed description.

## 4.2 DC Parameters

### 4.2.1 Input/Output Characteristics

**Table 34 Input/Output Characteristics (Operating Conditions apply)**

| Parameter  | Symbol        | Limit Values          |                      | Unit | Test Conditions   |
|--|---------------|-----------------------|----------------------|------|-------------------|
|  |               | min.                  | max.                 |      |                   |
| <b><math>V_{DDP} = 5V</math> Range</b>                   |               |                       |                      |      |                   |
| Output low voltage                                       | $V_{OL}$ CC   | –                     | 1.0                  | V    | $I_{OL} = 15$ mA  |
|  |               | –                     | 0.4                  | V    | $I_{OL} = 5$ mA   |
| Output high voltage                                      | $V_{OH}$ CC   | $V_{DDP} - 1.0$       | –                    | V    | $I_{OH} = -15$ mA |
|  |               | $V_{DDP} - 0.4$       | –                    | V    | $I_{OH} = -5$ mA  |
| Input low voltage on port pins (all except P0.0 & P0.1)  | $V_{ILP}$ SR  | –                     | $0.3 \times V_{DDP}$ | V    | CMOS Mode         |
| Input low voltage on P0.0 & P0.1                         | $V_{ILP0}$ SR | -0.2                  | $0.3 \times V_{DDP}$ | V    | CMOS Mode         |
| Input low voltage on RESET pin                           | $V_{ILR}$ SR  | –                     | $0.3 \times V_{DDP}$ | V    | CMOS Mode         |
| Input low voltage on TMS pin                             | $V_{ILT}$ SR  | –                     | $0.3 \times V_{DDP}$ | V    | CMOS Mode         |
| Input high voltage on port pins (all except P0.0 & P0.1) | $V_{IHP}$ SR  | $0.7 \times V_{DDP}$  | –                    | V    | CMOS Mode         |
| Input high voltage on P0.0 & P0.1                        | $V_{IHP0}$ SR | $0.7 \times V_{DDP}$  | $V_{DDP}$            | V    | CMOS Mode         |
| Input high voltage on RESET pin                          | $V_{IHR}$ SR  | $0.7 \times V_{DDP}$  | –                    | V    | CMOS Mode         |
| Input high voltage on TMS pin                            | $V_{IHT}$ SR  | $0.75 \times V_{DDP}$ | –                    | V    | CMOS Mode         |
| Input Hysteresis <sup>1)</sup> on Port Pins              | $HYS$ CC      | $0.08 \times V_{DDP}$ | –                    | V    | CMOS Mode         |
| Input Hysteresis <sup>1)</sup> on XTAL1                  | $HYSXCC$      | $0.07 \times V_{DDC}$ | –                    | V    |                   |

**Table 34 Input/Output Characteristics (Operating Conditions apply)**

| Parameter  | Symbol           |    | Limit Values         |                      | Unit          | Test Conditions  |
|--|------------------|----|----------------------|----------------------|---------------|--|
|  |                  |    | min.                 | max.                 |               |  |
| Input low voltage at XTAL1                                       | $V_{ILX}$        | SR | $V_{SS} - 0.5$       | $0.3 \times V_{DDC}$ | V             |  |
| Input high voltage at XTAL1                                      | $V_{IHx}$        | SR | $0.7 \times V_{DDC}$ | $V_{DDC} + 0.5$      | V             |  |
| Pull-up current  | $I_{PU}$         | SR | -                    | -10                  | $\mu\text{A}$ | $V_{IH,min}$   |
|  |                  |    | -150                 | -                    | $\mu\text{A}$ | $V_{IL,max}$   |
| Pull-down current  | $I_{PD}$         | SR | -                    | 10                   | $\mu\text{A}$ | $V_{IL,max}$   |
|  |                  |    | 150                  | -                    | $\mu\text{A}$ | $V_{IH,min}$   |
| Input leakage current <sup>2)</sup>                              | $I_{OZ1}$        | CC | -2                   | 2                    | $\mu\text{A}$ | $0 < V_{IN} < V_{DDP}$ ,<br>$T_A \leq 140^\circ\text{C}$ |
| Input current at XTAL1   | $I_{ILX}$        | CC | -10                  | 10                   | $\mu\text{A}$ |  |
| Overload current on any pin                                      | $I_{OV}$         | SR | -5                   | 5                    | $\text{mA}$   |  |
| Absolute sum of overload currents                                | $\Sigma I_{OV} $ | SR | -                    | 25                   | $\text{mA}$   | <sup>3)</sup>  |
| Voltage on any pin during $V_{DDP}$ power off                    | $V_{PO}$         | SR | -                    | 0.3                  | V             | <sup>4)</sup>  |
| Maximum current per pin (excluding $V_{DDP}$ and $V_{SS}$ )      | $I_M$            | SR | -                    | 15                   | $\text{mA}$   |  |
| Maximum current for all pins (excluding $V_{DDP}$ and $V_{SS}$ ) | $\Sigma I_M $    | SR | -                    | 60                   | $\text{mA}$   |  |
| Maximum current into $V_{DDP}$                                   | $I_{MVDDP}$      | SR | -                    | 80                   | $\text{mA}$   |  |
| Maximum current out of $V_{SS}$                                  | $I_{MVSS}$       | SR | -                    | 80                   | $\text{mA}$   |  |

<sup>1)</sup> Not subjected to production test, verified by design/characterization. Hysteresis is implemented to avoid meta stable states and switching due to internal ground bounce. It cannot be guaranteed that it suppresses switching due to external system noise.

<sup>2)</sup> An additional error current ( $I_{INJ}$ ) will flow if an overload current flows through an adjacent pin. TMS pin and RESET pin have internal pull devices and are not included in the input leakage current characteristic.

<sup>3)</sup> Not subjected to production test, verified by design/characterization.

4) Not subjected to production test, verified by design/characterization. However, for applications with strict low power-down current requirements, it is mandatory that no active voltage source is supplied at any GPIO pin when VDDP is powered off.

### 4.2.2 Supply Threshold Characteristics

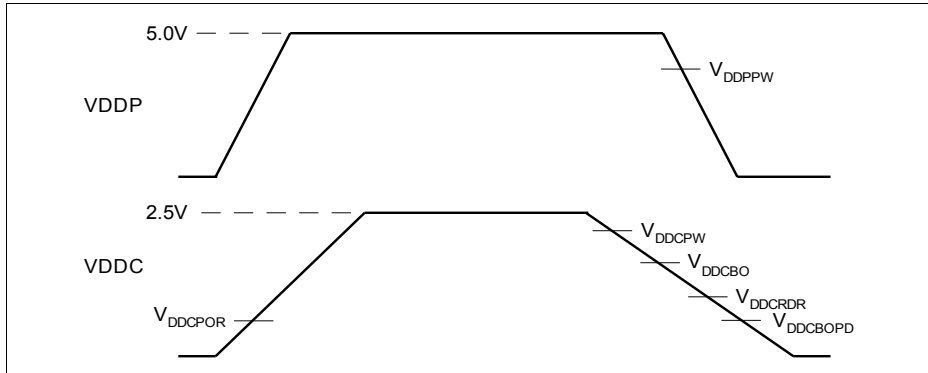

**Figure 36 Supply Threshold Parameters**

**Table 35 Supply Threshold Parameters (Operating Conditions apply)**

| Parameters   | Symbol               |    | Limit Values |      |      | Unit |
|--|----------------------|----|--------------|------|------|------|
|  |                      |    | min.         | typ. | max. |      |
| V <sub>DDC</sub> prewarning voltage <sup>1)</sup>                  | V <sub>DDCPW</sub>   | CC | 2.2          | 2.3  | 2.4  | V    |
| V <sub>DDC</sub> brownout voltage in active mode <sup>1)</sup>     | V <sub>DDCBO</sub>   | CC | 2.0          | 2.1  | 2.2  | V    |
| RAM data retention voltage   | V <sub>DDCRDR</sub>  | CC | 0.9          | 1.0  | 1.1  | V    |
| V <sub>DDC</sub> brownout voltage in power-down mode <sup>2)</sup> | V <sub>DDCBOPD</sub> | CC | 1.3          | 1.5  | 1.7  | V    |
| V <sub>DDP</sub> prewarning voltage <sup>3)</sup>                  | V <sub>DDPPW</sub>   | CC | 3.3          | 4.0  | 4.65 | V    |
| Power-on reset voltage <sup>2)4)</sup>                             | V <sub>DDCPOR</sub>  | CC | 1.3          | 1.5  | 1.7  | V    |

1) Detection is disabled in power-down mode.

2) Detection is enabled in both active and power-down mode.

3) Detection is enabled for external power supply of 5.0V.

4) The reset of EVR is extended by 300 μs typically after the VDDC reaches the power-on reset voltage.

**4.2.3 ADC Characteristics**

The values in the table below are given for an analog power supply between 4.5 V to 5.5 V. All ground pins ( $V_{SS}$ ) must be externally connected to one single star point in the system. The voltage difference between the ground pins must not exceed 200mV.

**Table 36 ADC Characteristics (Operating Conditions apply;  $V_{DDP} = 5V$  Range)**

| Parameter   | Symbol               | Limit Values                        |           |                  | Unit    | Test Conditions/<br>Remarks                            |
|---|----------------------|-------------------------------------|-----------|------------------|---------|--|
|   |                      | min.                                | typ .     | max.             |         |  |
| Analog reference voltage                            | $V_{AREF}$<br>SR     | $V_{AGND} + 1$                      | $V_{DDP}$ | $V_{DDP} + 0.05$ | V       |  |
| Analog reference ground                             | $V_{AGND}$<br>SR     | $V_{SS} - 0.05$                     | $V_{SS}$  | $V_{AREF} - 1$   | V       |  |
| Analog input voltage range                          | $V_{AIN}$ SR         | $V_{AGND}$                          | –         | $V_{AREF}$       | V       |  |
| ADC clocks  | $f_{ADC}$            | –                                   | 20        | 40               | MHz     | module clock   |
|   | $f_{ADCI}$           | –                                   | –         | 10               | MHz     | internal analog clock<br>See <a href="#">Figure 33</a> |
| Sample time   | $t_S$ CC             | $(2 + INPCR0.STC) \times t_{ADCI}$  |           |                  | $\mu s$ |  |
| Conversion time                                     | $t_C$ CC             | See <a href="#">Section 4.2.3.1</a> |           |                  | $\mu s$ |  |
| Total unadjusted error                              | TUE <sup>1)</sup> CC | –                                   | –         | $\pm 1$          | LSB     | 8-bit conversion. <sup>2)</sup>                        |
|   |                      | –                                   | –         | $\pm 2$          | LSB     | 10-bit conversion.                                     |
| Differential Nonlinearity                           | DNL CC               | –                                   | $\pm 1$   | –                | LSB     | 10-bit conversion <sup>2)</sup>                        |
| Integral Nonlinearity                               | INL CC               | –                                   | $\pm 1$   | –                | LSB     | 10-bit conversion <sup>2)</sup>                        |
| Offset  | OFF CC               | –                                   | $\pm 1$   | –                | LSB     | 10-bit conversion <sup>2)</sup>                        |
| Gain  | GAIN CC              | –                                   | $\pm 1$   | –                | LSB     | 10-bit conversion <sup>2)</sup>                        |
| Switched capacitance at the reference voltage input | $C_{AREFSW}$<br>CC   | –                                   | 10        | 20               | pF      | <sup>2)3)</sup>  |
| Switched capacitance at the analog voltage inputs   | $C_{AINSW}$<br>CC    | –                                   | 5         | 7                | pF      | <sup>2)4)</sup>  |

**Electrical Parameters**
**Table 36 ADC Characteristics (Operating Conditions apply;  $V_{DDP} = 5V$  Range)**

| Parameter                                       | Symbol       | Limit Values |       |      | Unit      | Test Conditions/<br>Remarks |
|---|--------------|--------------|-------|------|-----------|-----------------------------|
|   |              | min.         | typ . | max. |           |                             |
| Input resistance of the reference input         | $R_{AREFCC}$ | –            | 1     | 2    | $k\Omega$ | 2)                          |
| Input resistance of the selected analog channel | $R_{AIN CC}$ | –            | 1     | 1.5  | $k\Omega$ | 2)                          |

1) TUE is tested at  $V_{AREF} = 5.0 V$ ,  $V_{AGND} = 0 V$ ,  $V_{DDP} = 5.0 V$ .

2) Not subject to production test, verified by design/characterization.

3) This represents an equivalent switched capacitance. This capacitance is not switched to the reference voltage at once. Instead of this, smaller capacitances are successively switched to the reference voltage.

4) The sampling capacity of the conversion C-Network is pre-charged to  $V_{AREF}/2$  before connecting the input to the C-Network. Because of the parasitic elements, the voltage measured at ANx is lower than  $V_{AREF}/2$ .



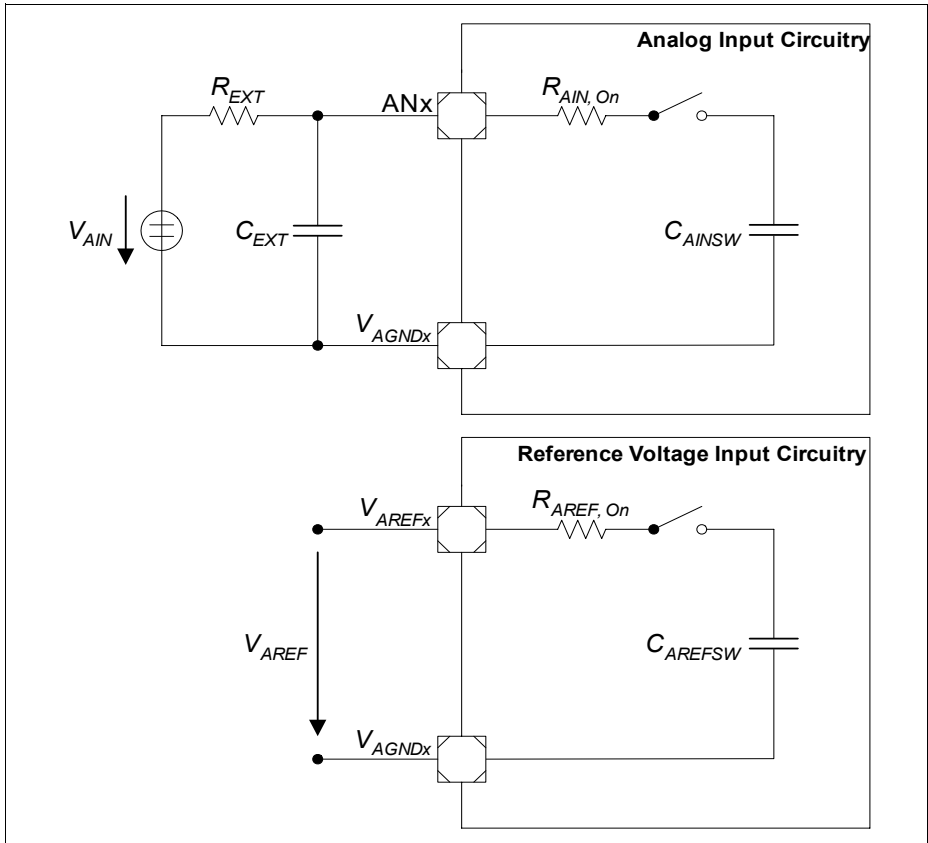

Figure 37 ADC Input Circuits

#### 4.2.3.1 ADC Conversion Timing

Conversion time,  $t_C = t_{ADC} \times ( 1 + r \times ( 3 + n + STC ) )$ , where

$r = CTC + 2$  for  $CTC = 00_B, 01_B$  or  $10_B$ ,

$r = 32$  for  $CTC = 11_B$ ,

$CTC =$  Conversion Time Control (GLOBCTR.CTC),

$STC =$  Sample Time Control (INPCR0.STC),

$n = 8$  or  $10$  (for 8-bit and 10-bit conversion respectively),

$t_{ADC} = 1 / f_{ADC}$

**4.2.4 Power Supply Current**
**Table 37 Power Supply Current Parameters (Operating Conditions apply;  
 $V_{DDP} = 5V$  range )**

| Parameter                              | Symbol    | Limit Values       |                    | Unit | Test Condition |
|--|-----------|--------------------|--------------------|------|----------------|
|  |           | typ. <sup>1)</sup> | max. <sup>2)</sup> |      |                |
| <b><math>V_{DDP} = 5V</math> Range</b> |           |                    |                    |      |                |
| Active Mode                            | $I_{DDP}$ | 22.6               | 24.5               | mA   | <sup>3)</sup>  |
| Idle Mode                              | $I_{DDP}$ | 17.2               | 19.7               | mA   | <sup>4)</sup>  |
| Active Mode with slow-down enabled     | $I_{DDP}$ | 7.2                | 8.2                | mA   | <sup>5)</sup>  |
| Idle Mode with slow-down enabled       | $I_{DDP}$ | 7.1                | 8                  | mA   | <sup>6)</sup>  |

<sup>1)</sup> The typical  $I_{DDP}$  values are periodically measured at  $T_A = +25\text{ °C}$  and  $V_{DDP} = 5.0\text{ V}$ .

<sup>2)</sup> The maximum  $I_{DDP}$  values are measured under worst case conditions ( $T_A = +140\text{ °C}$  and  $V_{DDP} = 5.5\text{ V}$ ).

<sup>3)</sup>  $I_{DDP}$  (active mode) is measured with: CPU clock and input clock to all peripherals running at 26.7 MHz (set by on-chip oscillator of 10 MHz and NDIV in PLL\_CON to 0010<sub>B</sub>),  $\overline{\text{RESET}} = V_{DDP}$ .

<sup>4)</sup>  $I_{DDP}$  (idle mode) is measured with: CPU clock disabled, watchdog timer disabled, input clock to all peripherals enabled and running at 26.7 MHz,  $\overline{\text{RESET}} = V_{DDP}$ .

<sup>5)</sup>  $I_{DDP}$  (active mode with slow-down mode) is measured with: CPU clock and input clock to all peripherals running at 833 KHz by setting CLKREL in CMCON to 0101<sub>B</sub>,  $\overline{\text{RESET}} = V_{DDP}$ .

<sup>6)</sup>  $I_{DDP}$  (idle mode with slow-down mode) is measured with: CPU clock disabled, watchdog timer disabled, input clock to all peripherals enabled and running at 833 KHz by setting CLKREL in CMCON to 0101<sub>B</sub>,  $\overline{\text{RESET}} = V_{DDP}$ .

**Electrical Parameters**
**Table 38 Power Down Current (Operating Conditions apply;  $V_{DDP} = 5V$  range )**

| Parameter                              | Symbol    | Limit Values       |                    | Unit    | Test Condition                                 |
|--|-----------|--------------------|--------------------|---------|--|
|  |           | typ. <sup>1)</sup> | max. <sup>2)</sup> |         |  |
| <b><math>V_{DDP} = 5V</math> Range</b> |           |                    |                    |         |  |
| Power-Down Mode <sup>3)</sup>          | $I_{PDP}$ | 1                  | 10                 | $\mu A$ | $T_A = + 25\text{ }^\circ C$ . <sup>4)</sup>   |
|  |           | -                  | 30                 | $\mu A$ | $T_A = + 85\text{ }^\circ C$ . <sup>4)5)</sup> |

1) The typical  $I_{PDP}$  values are measured at  $V_{DDP} = 5.0\text{ V}$ .

2) The maximum  $I_{PDP}$  values are measured at  $V_{DDP} = 5.5\text{ V}$ .

3)  $I_{PDP}$  (power-down mode) has a maximum value of  $400\text{ }\mu A$  at  $T_A = + 140\text{ }^\circ C$ .

4)  $I_{PDP}$  (power-down mode) is measured with:  $\overline{RESET} = V_{DDP}$ ,  $V_{AGND} = V_{SS}$ ,  $RXD/INT0 = V_{DDP}$ ; rest of the ports are programmed to be input with either internal pull devices enabled or driven externally to ensure no floating inputs.

5) Not subject to production test, verified by design/characterization.

### 4.3 AC Parameters

#### 4.3.1 Testing Waveforms

The testing waveforms for rise/fall time, output delay and output high impedance are shown in **Figure 38**, **Figure 39** and **Figure 40**.

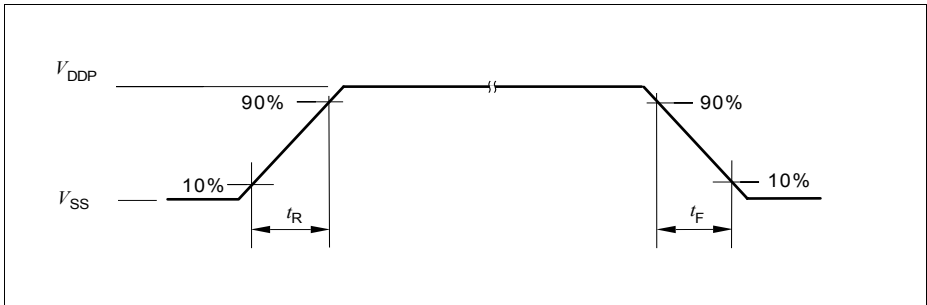

**Figure 38** Rise/Fall Time Parameters

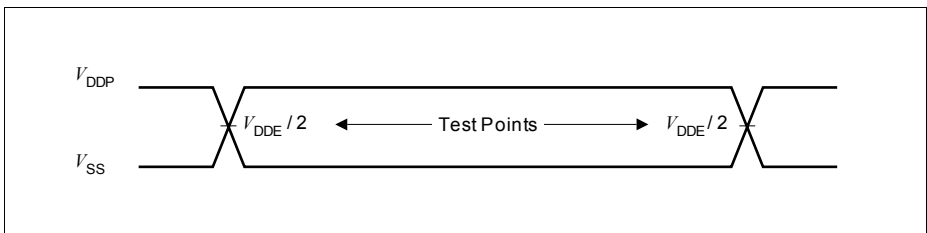

**Figure 39** Testing Waveform, Output Delay

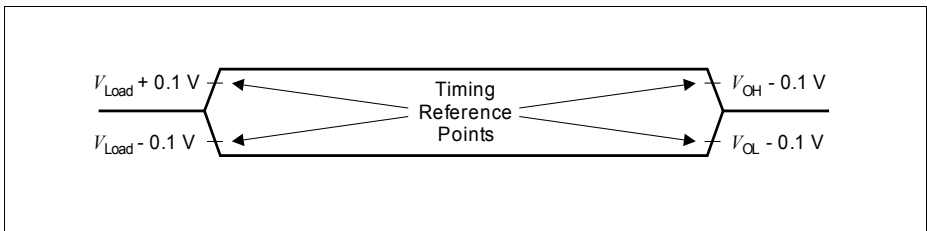

**Figure 40** Testing Waveform, Output High Impedance

### 4.3.2 Output Rise/Fall Times

**Table 39 Output Rise/Fall Times Parameters (Operating Conditions apply)**

| Parameter                              | Symbol     | Limit Values |      | Unit | Test Conditions      |
|--|------------|--------------|------|------|----------------------|
|  |            | min.         | max. |      |                      |
| <b><math>V_{DDP} = 5V</math> Range</b> |            |              |      |      |                      |
| Rise/fall times <sup>1) 2)</sup>       | $t_R, t_F$ | –            | 10   | ns   | 20 pF. <sup>3)</sup> |

- 1) Rise/Fall time measurements are taken with 10% - 90% of the pad supply.
- 2) Not all parameters are 100% tested, but are verified by design/characterization and test correlation.
- 3) Additional rise/fall time valid for  $C_L = 20pF - 100pF @ 0.125 ns/pF$ .

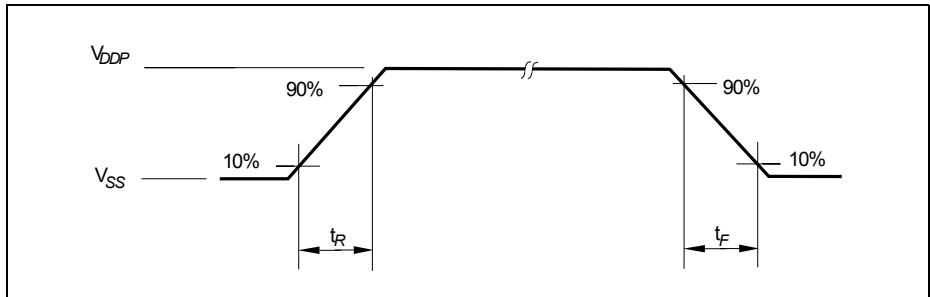

**Figure 41 Rise/Fall Times Parameters**

### 4.3.3 Power-on Reset and PLL Timing

**Table 40 Power-On Reset and PLL Timing (Operating Conditions apply)**

| Parameter                                  | Symbol         | Limit Values |      |      | Unit    | Test Conditions                                 |
|--|----------------|--------------|------|------|---------|---|
|  |                | min.         | typ. | max. |         |   |
| Pad operating voltage                      | $V_{PAD}$ CC   | 2.3          | –    | –    | V       |   |
| On-Chip Oscillator start-up time           | $t_{OSCST}$ CC | –            | –    | 500  | ns      |   |
| Flash initialization time                  | $t_{FINIT}$ CC | –            | 160  | –    | $\mu$ s |   |
| $\overline{RESET}$ hold time <sup>1)</sup> | $t_{RST}$ SR   | –            | 500  | –    | $\mu$ s | $V_{DDP}$ rise time (10% – 90%) $\leq 500\mu$ s |
| PLL lock-in in time                        | $t_{LOCK}$ CC  | –            | –    | 200  | $\mu$ s |   |
| PLL accumulated jitter                     | $D_P$          | –            | –    | 0.7  | ns      | 2)  |

1)  $\overline{RESET}$  signal has to be active (low) until  $V_{DDC}$  has reached 90% of its maximum value (typ. 2.5V).

2) PLL lock at 80 MHz using a 4 MHz external oscillator. The PLL Divider settings are K = 2, N = 40 and P = 1.

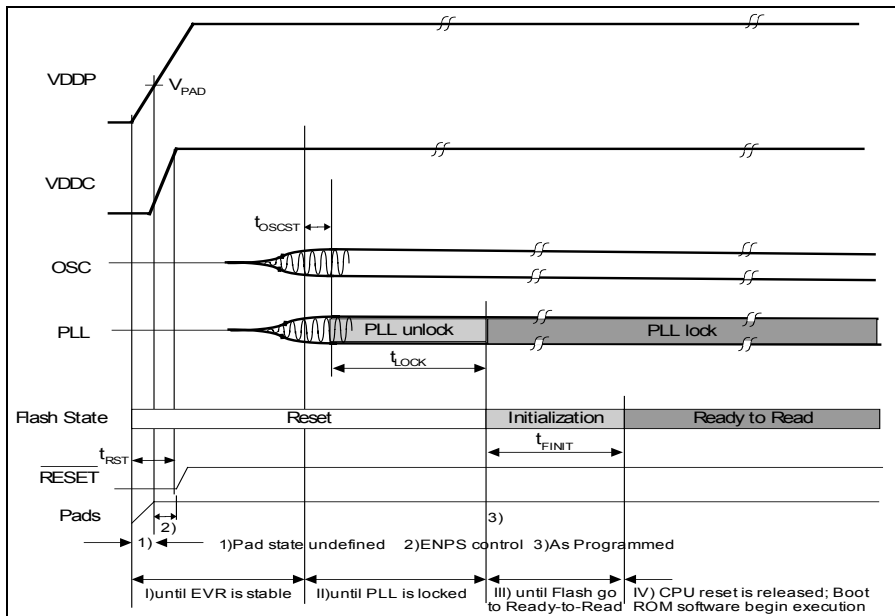

**Figure 42 Power-on Reset Timing**

**4.3.4 On-Chip Oscillator Characteristics**
**Table 41 On-chip Oscillator Characteristics (Operating Conditions apply)**

| Parameter                                   | Symbol             | Limit Values |      |       | Unit | Test Conditions   |
|---|--------------------|--------------|------|-------|------|---|
|   |                    | min.         | typ. | max.  |      |   |
| Nominal frequency                           | $f_{NOM}$ CC       | 9.75         | 10   | 10.25 | MHz  | under nominal conditions <sup>1)</sup> after IFX-backend trimming   |
| Long term frequency deviation <sup>2)</sup> | $\Delta f_{LT}$ CC | -5.0         | –    | 5.0   | %    | with respect to $f_{NOM}$ , over lifetime and temperature (–10°C to 140°C), for one device after trimming |
|   |                    | -6.0         | –    | 0     | %    | with respect to $f_{NOM}$ , over lifetime and temperature (–40°C to –10°C), for one device after trimming |
| Short term frequency deviation              | $\Delta f_{ST}$ CC | -1.0         | –    | 1.0   | %    | with respect to $f_{NOM}$ , within one LIN message (<10 ms ... 100 ms)                                    |

<sup>1)</sup> Nominal condition:  $V_{DDC} = 2.5\text{ V}$ ,  $T_A = +25^\circ\text{C}$ .

<sup>2)</sup> Not all parameters are 100% tested, but are verified by design/characterization and test correlation.

### 4.3.5 JTAG Timing

**Table 42 TCK Clock Timing (Operating Conditions apply;  $C_L = 50$  pF)**



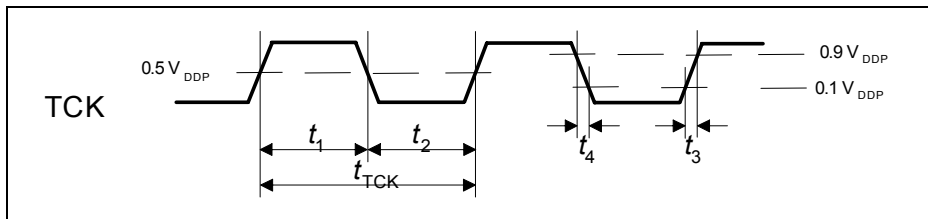



| Parameter           | Symbol       | Limits |     | Unit |
|---------------------|--------------|--------|-----|------|
|                     |              | min    | max |      |
| TCK clock period    | $t_{TCK}$ SR | 50     | –   | ns   |
| TCK high time       | $t_1$ SR     | 20     | –   | ns   |
| TCK low time        | $t_2$ SR     | 20     | –   | ns   |
| TCK clock rise time | $t_3$ SR     | –      | 4   | ns   |
| TCK clock fall time | $t_4$ SR     | –      | 4   | ns   |

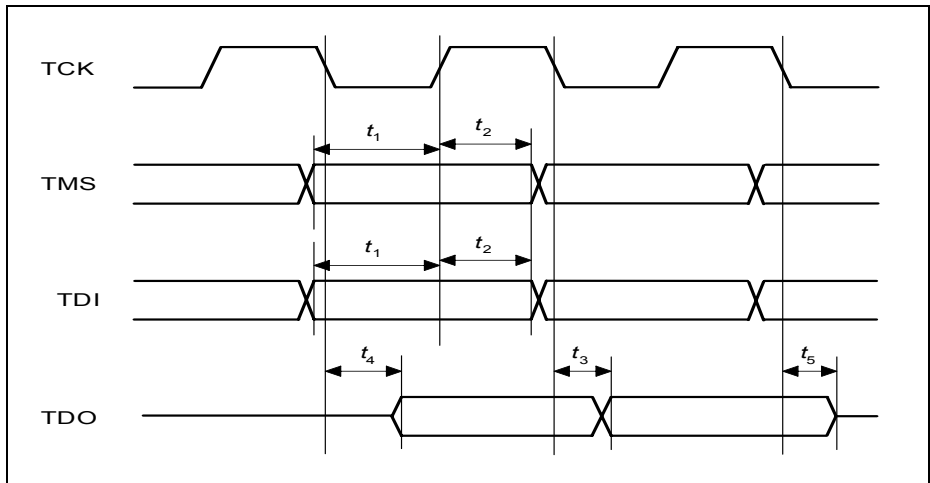

**Figure 43 TCK Clock Timing**



**Table 43 JTAG Timing (Operating Conditions apply;  $C_L = 50$  pF)**

| Parameter   | Symbol   | Limits |     | Unit |
|---|----------|--------|-----|------|
|   |          | min    | max |      |
| TMS setup to TCK                             | $t_1$ SR | 8.0    | –   | ns   |
| TMS hold to TCK                              | $t_2$ SR | 5.0    | –   | ns   |
| TDI setup to TCK                             | $t_1$ SR | 11.0   | –   | ns   |
| TDI hold to TCK                              | $t_2$ SR | 6.0    | –   | ns   |
| TDO valid output from TCK                    | $t_3$ CC | –      | 23  | ns   |
| TDO high impedance to valid output from TCK  | $t_4$ CC | –      | 26  | ns   |
| TDO valid output to high impedance from TCK  | $t_5$ CC | –      | 18  | ns   |



**Figure 44 JTAG Timing**

### 4.3.6 SSC Master Mode Timing

**Table 44 SSC Master Mode Timing (Operating Conditions apply;  $C_L = 50$  pF)**

| Parameter             | Symbol |    | Limit Values           |      | Unit |
|-----------------------|--------|----|------------------------|------|------|
|                       |        |    | min.                   | max. |      |
| SCLK clock period     | $t_0$  | CC | $2 \cdot T_{SSC}^{1)}$ | –    | ns   |
| MTRSR delay from SCLK | $t_1$  | CC | 0                      | 8    | ns   |
| MRST setup to SCLK    | $t_2$  | SR | 22                     | –    | ns   |
| MRST hold from SCLK   | $t_3$  | SR | 0                      | –    | ns   |

<sup>1)</sup>  $T_{SSCmin} = T_{CPU} = 1/f_{CPU}$ . When  $f_{CPU} = 26.7$  MHz,  $t_0 = 74.9$  ns.  $T_{CPU}$  is the CPU clock period.

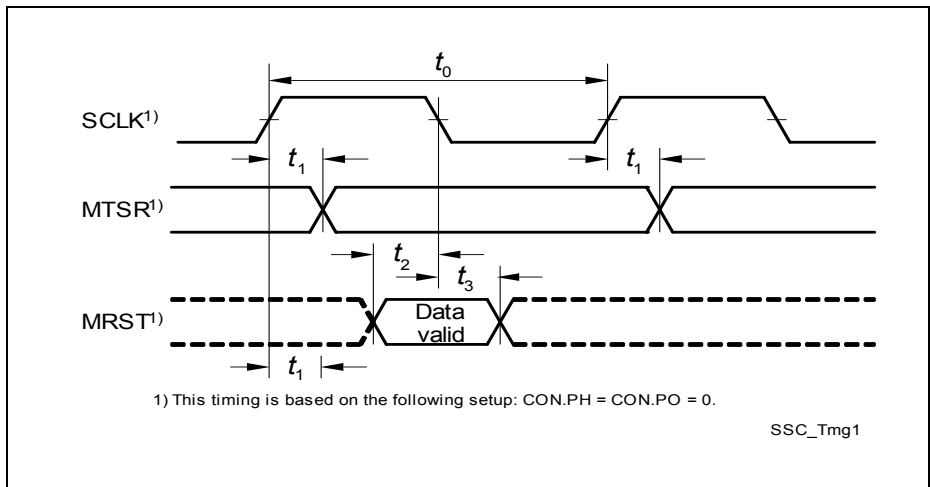

<sup>1)</sup> This timing is based on the following setup: CON.PH = CON.PO = 0.

**Figure 45 SSC Master Mode Timing**

## 5 Package and Reliability

### 5.1 Package Parameters (PG-TSSOP-38)

Table 45 provides the thermal characteristics of the package.

**Table 45 Thermal Characteristics of the Package**

| Parameter                                      | Symbol       | Limit Values |      | Unit | Notes |
|--|--------------|--------------|------|------|-------|
|  |              | Min.         | Max. |      |       |
| Thermal resistance junction case <sup>1)</sup> | $R_{TJC}$ CC | –            | 15.7 | K/W  | –     |
| Thermal resistance junction lead <sup>1)</sup> | $R_{TJL}$ CC | –            | 39.2 | K/W  | –     |

<sup>1)</sup> The thermal resistances between the case and the ambient ( $R_{TCA}$ ), the lead and the ambient ( $R_{TLA}$ ) are to be combined with the thermal resistances between the junction and the case ( $R_{TJC}$ ), the junction and the lead ( $R_{TJL}$ ) given above, in order to calculate the total thermal resistance between the junction and the ambient ( $R_{TJA}$ ). The thermal resistances between the case and the ambient ( $R_{TCA}$ ), the lead and the ambient ( $R_{TLA}$ ) depend on the external system (PCB, case) characteristics, and are under user responsibility.

The junction temperature can be calculated using the following equation:  $T_J = T_A + R_{TJA} \times P_D$ , where the  $R_{TJA}$  is the total thermal resistance between the junction and the ambient. This total junction ambient resistance  $R_{TJA}$  can be obtained from the upper four partial thermal resistances, by

- a) simply adding only the two thermal resistances (junction lead and lead ambient), or
- b) by taking all four resistances into account, depending on the precision needed.

## 5.2 Package Outline

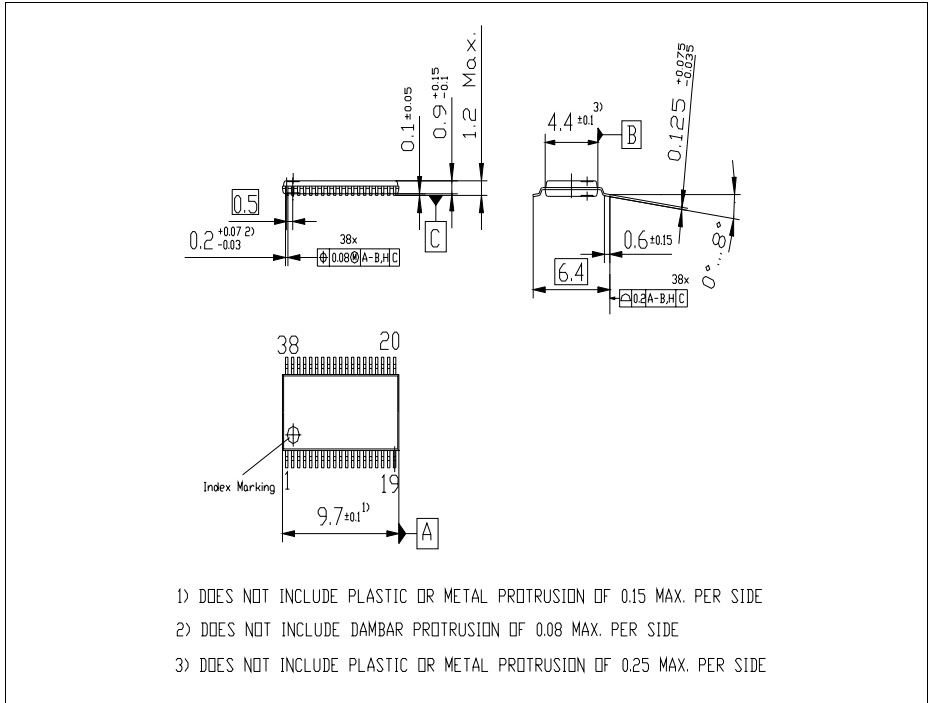

Figure 46 PG-TSSOP-38-4 Package Outline

### 5.3 Quality Declaration

**Table 46** shows the characteristics of the quality parameters in the SAA-XC866.

**Table 46 Quality Parameters**

| Parameter   | Symbol    | Limit Values |       | Unit  | Notes                           |
|---|-----------|--------------|-------|-------|---------------------------------|
|   |           | Min.         | Max.  |       |                                 |
| Operation Lifetime <sup>1)</sup>                                | $t_{OP}$  | –            | 500   | hours | $T_A = 140^\circ\text{C}$       |
|   |           | –            | 2000  | hours | $T_A = 125^\circ\text{C}$       |
|   |           | –            | 10000 | hours | $T_A = 85^\circ\text{C}$        |
|   |           | –            | 1500  | hours | $T_A = -40^\circ\text{C}$       |
| ESD susceptibility according to Human Body Model (HBM)          | $V_{HBM}$ | –            | 2000  | V     | Conforming to EIA/JESD22-A114-B |
| ESD susceptibility according to Charged Device Model (CDM) pins | $V_{CDM}$ | –            | 500   | V     | Conforming to JESD22-C101-C     |

<sup>1)</sup> This lifetime refers only to the time when the device is powered-on.

<http://www.infineon.com>